

Babelyuk Valeriy Ye, Babelyuk Nazariy V, Popovych Igor L, Dobrovol's'kyi Yuriy G, Korsuns'kyi Igor H, Korolyshyn Tetyana A, Kindzer Bohdan M, Zukow Walery. Influence of the course of electrostimulation by the device "VEB-1" on parameters of electroencephalogram at practically healthy males. *Journal of Education, Health and Sport*. 2018;8(4):195-206. eISSN 2391-8306. DOI <http://dx.doi.org/10.5281/zenodo.1219029> <http://ojs.ukw.edu.pl/index.php/johs/article/view/5416>

The Journal has had 7 points in Ministry of Science and Higher Education parametric evaluation. Part B item 1223 (26.01.2017).
1223 Journal of Education, Health and Sport eISSN 2391-8306 7

© The Author(s) 2018;

This article is published with open access at Licensee Open Journal Systems of Kazimierz Wielki University in Bydgoszcz, Poland

Open Access. This article is distributed under the terms of the Creative Commons Attribution Noncommercial License which permits any noncommercial use, distribution, and reproduction in any medium, provided the original author(s) and source are credited. This is an open access article licensed under the terms of the Creative Commons Attribution Non Commercial License (<http://creativecommons.org/licenses/by-nc/4.0/>) which permits unrestricted, non commercial use, distribution and reproduction in any medium, provided the work is properly cited.

This is an open access article licensed under the terms of the Creative Commons Attribution Non Commercial License (<http://creativecommons.org/licenses/by-nc/4.0/>) which permits unrestricted, non commercial use, distribution and reproduction in any medium, provided the work is properly cited.

The authors declare that there is no conflict of interests regarding the publication of this paper.

Received: 01.02.2018. Revised 12.03.2018. Accepted: 16.04.2018.

Influence of the course of electrostimulation by the device "VEB-1" on parameters of electroencephalogram at practically healthy males

Valeriy Ye Babelyuk^{1,2}, Nazariy V Babelyuk^{1,2}, Igor L Popovych³,
Yuriy G Dobrovol's'kyi^{4,5}, Igor H Korsuns'kyi^{4,5}, Tetyana A Korolyshyn^{1,3},
Bohdan M Kindzer⁶, Walery Zukow⁷

¹Clinical Sanatorium "Moldova", Truskavets', Ukraine san.moldova.tr@ukr.net

²Ukrainian SR Institute of Transport Medicine Ministry of Health, Odessa, Ukraine

³Bohomolets' Institute of Physiology of NAS, Kyïv, Ukraine

i.popovych@biph.kiev.ua

⁴Chernivtsi National University named after. Yu. Fedkovych, Chernivtsi, Ukraine

yuriydr@ukr.net

⁵Research and Production Company "Tensor", Chernivtsi, Ukraine

⁶State University of Physical Culture, L'viv, Ukraine BogdanKindzer@ukr.net

⁷Department of Spatial Management and Tourism, Faculty of Earth

Sciences, Nicolaus Copernicus University, Torun, Poland w.zukow@wp.pl

Abstract

Background. We created and patented device for electrostimulation "VEB-1". It is intended for activation of functional systems of organism by wave influence on nerve plexus by frequency beats method. This article launches a series of articles on the influence of this device on the parameters of the neuroendocrine-immune complex and the metabolism of various categories of people. **Materials and Methods.** The object of observation were 14 males aged 24-59 years without clinical diagnose but with dysfunction of neuro-endocrine-immune complex and metabolism. In the basal conditions we recorded electroencephalogram (EEG) a hardware-software complex "NeuroCom Standard" (KhAI Medica, Kharkiv, Ukraine). Then the volunteers were subjected to an electrostimulation session lasted for 21 minutes in four days. One day after the last session, the EEG was re-registered. **Results.** 20 parameters of EEG were identified, in which the volunteers' neurodynamics before and after the course of electrostimulation differed considerably (Squared Mahalanobis Distance make up 191; $F=16,7$; $p<10^{-3}$). The neurotropic stimulation effect has a modulating character, namely: the initially decreased spectral power density (SPD) of the alpha-rhythm in F3, F4, T4, T5 loci as well as of theta-rhythm in P3 locus increases; decreased SPD of beta-rhythm in the F3, C3, C4, P3, P4 and O2 loci as well as Amplitude of beta-rhythm becomes even smaller; the initially increased SPD of delta-rhythm in the loci Fp1, F8 and P4 rises further. **Conclusion.** A four-day electrostimulation course causes on males with dysfunction of the

neuro-endocrine-immune complex and metabolism a notable neuro-modulating effect evaluated by changes in basal EEG.

Keywords. Device for electrostimulation, frequency beats method, electroencephalogram, neuro-modulating effect.

INTRODUCTION

The generator design for electrotherapy and stimulation of human nerve centers.

Conceiving and creating our device, we were based on the following provisions. The influence of impulses of a rectangular shape (range 7-18 Hz) made it possible to fix the frequency ranges of each basic nerve node. Low frequency had minimal effects of stimulation on the corresponding nerve node, while high frequency - the maximum. For the effective excitation of nerve centers, the frequency beat method is used. It consists in obtaining oscillations with close frequencies.

To obtain the effect of the frequency beats are generated by pulses of rectangular shape to two signal channels. The channels differ in frequency, which is the beat frequency. For example, for obtaining a beat frequency 6 Hz, forming pulses in a first channel to a carrier frequency of 30 Hz, a second channel at a frequency of 36 Hz. When the first pulse is formed on both channels with a phase shift of 0° , we obtain an absolute zero current in the output (Figure 1).

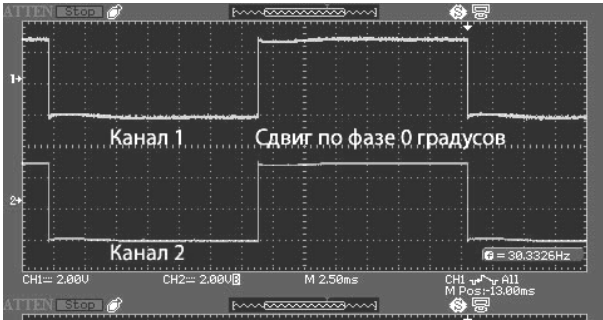

Fig. 1. Oscillogram of the first clock pulse

Figure 2 shows a periodic signal generated by frequency beats voltage in the two channels to form a common output signal (a). Also in Figure 2 is a graph of the current of the output signal (б). Such effect creates a shock wave through the object at the desired frequency. He also spins an electromagnetic field in the object.

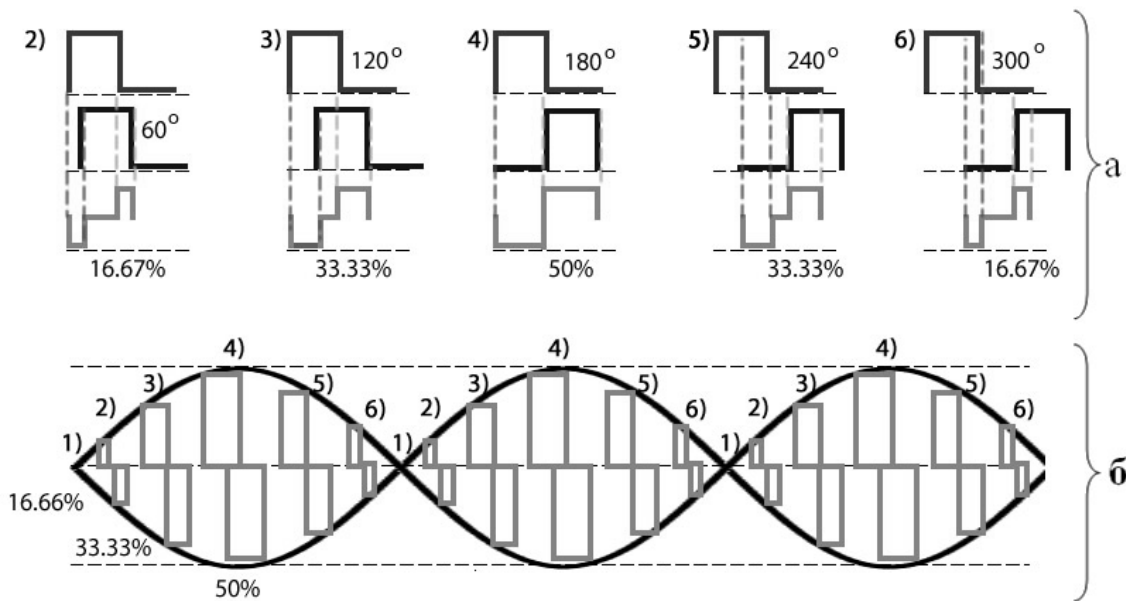

Fig. 2. Received by frequency beats a periodic signal (a) and a current diagram of the generated output signal (b)

The generator is assembled on the basis of the patent of Ukraine for utility model 105875 “Portable device for electrotherapy and stimulation” [4]. Its operation is described in [5].

The generator is assembled on the basis of a two-channel circuit using two frequency synthesizers, amplifiers, each of which generates its own frequency.

Figure 3 shows a block diagram of the device indicating the movement of electric current.

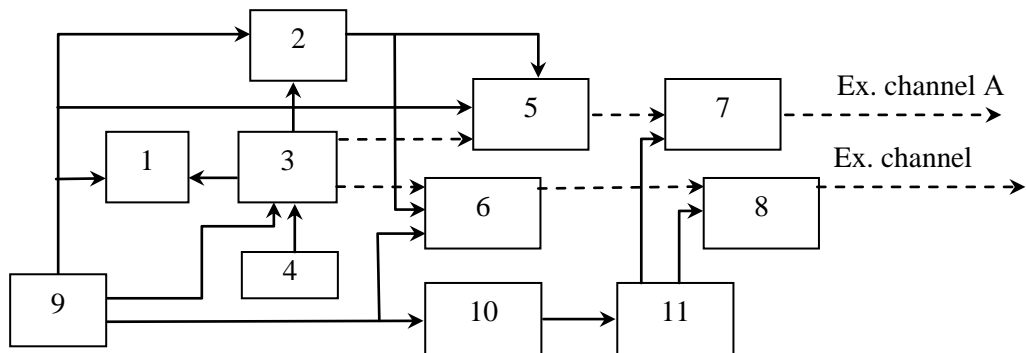

Fig. 3. A block diagram of the generator

1-display; 2-synthesizer of the signal with a sampling frequency up to 0,001 Hz; 3-micro-controller; 4-the encoder; 5-channel A signal synthesizer; 6-synthesizer of the channel B signal; 7-channel A signal amplifier; 8-the amplifier of a signal of the channel B; 9-battery 5 V; 10-voltage converter 5-24 V; 11-voltage regulator; 12-amplitude control of the output signal.

Table 1. The technical characteristics of the generator

Parameter	Parameter norm
The maximum power consumption, W	1,2
Output signal level by amplitude, V	3,6-16,2
The maximum amplitude of the output signal, V	16,2
The maximum possible current impact mA	25
Ripping protection when current exceeds 25 mA	yes
Operating current, mA	8-18
The shape of the output signal	Meander
Frequency range of action, Hz	144-1120
Power battery voltage, V	4,8-5,3
Continuous operation time, hours	8

Transmission of the electrical signal to the patient is carried out by means of contact copper electrodes through the wires. The generator operates as follows. Instrument software sets the operating frequency of the pulse beats 0,01-100 Hz with steps on each channel is not more than 0,001 Hz. Discreteness in each channel is not more than 0,001 Hz is provided by a clock synthesizer (2). It forms the frequency corresponding to the number of filling of the thirty two-bit synthesizer frequency (5,6) divided by 1000.

The appearance of the generator with a set of necessary equipment is shown in Figure 4.



Fig. 4. The appearance of the generator with a set of necessary equipment

1-generator VEB-1; 2-two cords with JACK connectors and terminal clamps for connection to OUT-A and OUT-B outputs; 3-contact pads or tubes; 4-power cable with connectors USB-B and USB-A; 5-battery 5 V.

MATERIAL AND RESEARCH METHODS

The object of observation were 14 males aged 24-59 years (including three authors) without clinical diagnose but with dysfunction of neuro-endocrine-immune complex and metabolism, characteristic for premorbid (intermediate between health and illness) state.

In the morning on an empty stomach we recorded electroencephalogram during 25 sec a hardware-software complex “NeuroCom Standard” (KhAI Medica, Kharkiv, Ukraine) monopolar in 16 loci (Fp1, Fp2, F3, F4, F7, F8, C3, C4, T3, T4, P3, P4, T5, T6, O1, O2) by 10-20 international system, with the reference electrodes A and Ref on tassels the ears. Among the options considered the average EEG amplitude (μV), average frequency (Hz), frequency deviation (Hz), index (%), coefficient of asymmetry (%), absolute ($\mu\text{V}^2/\text{Hz}$) and relative (%) spectral power density (SPD) of basic rhythms: β ($35 \div 13$ Hz), α ($13 \div 8$ Hz), θ ($8 \div 4$ Hz) and δ ($4 \div 0,5$ Hz) in all loci, according to the instructions of the device.

RESULTS AND DISCUSSION

Abstracts of the results of medical research published previously [1-3].

For the purpose of adequate comparative assessment changes in data EEG they are transformed into normalized parameter Z, calculated by formula [6]:

$Z=(V/N - 1)/Cv$; where

V is individual value of variable; N is its mean of normal (reference) value; Cv is coefficient of variation (SD/N) in norm.

For a qualitative estimation of deviations from the norm, we adopted the scale at which the Z-score in the range of $\pm 0,5$ Eukclidean units reflects the narrowed norm (green), the range $-1 \div +1$ reflects the expanded norm (yellow color), instead of going beyond the last we regard as a significant deviation from the norm (red color).

By the results of the screening of the Z values of the EEG parameters, we identified a series of patterns. The first pattern reflects an increase in the initially lower levels of SPD alpha- and theta- rhythms (Figure 5).

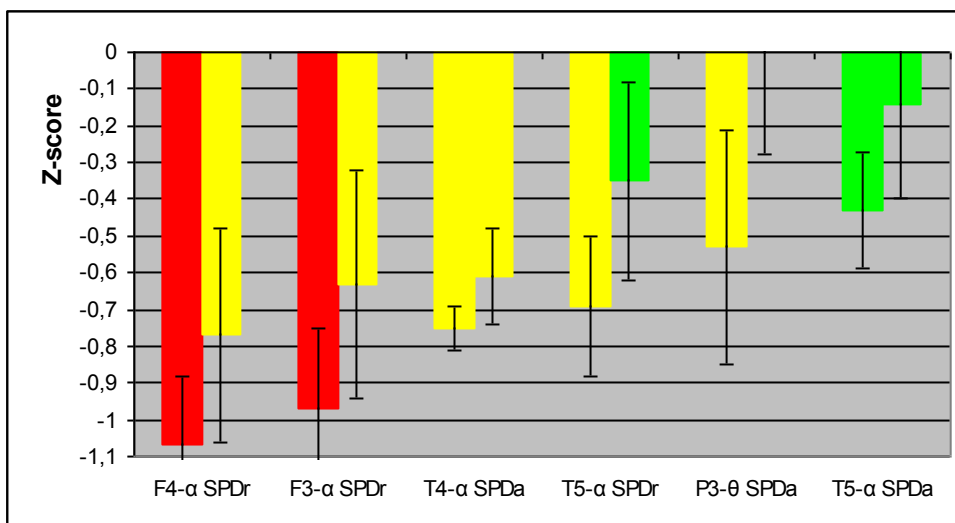

Fig. 5. Activating electrostimulation effects on the initially reduced EEG parameters. Here and in the future, in each pair of columns, the first reflects the initial level of the parameter, and the second - the final level (Mean \pm SE)

While moderately decreased SPD levels of beta-rhythm as well its Amplitude becomes even smaller. To this pattern we also included an increase in the Asymmetry of the theta-rhythm (Fig. 6).

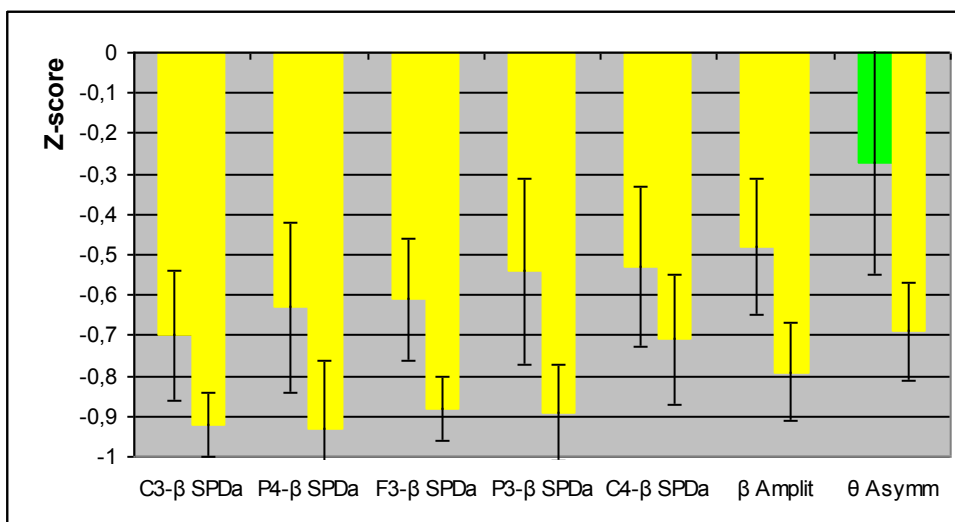

Fig. 6. Inhibiting electrostimulation effects on the initially reduced EEG parameters

The third pattern includes SPD of delta-rhythm, which initially were on the upper limit of the norm or were moderately elevated, and under the influence of electrical stimulation significantly increased, in particular in locus F8 drastically (Fig. 7).

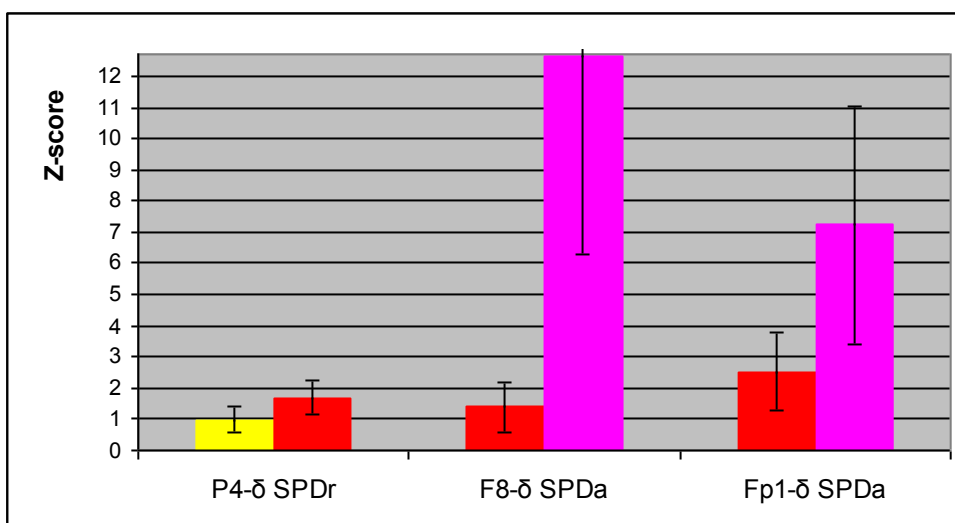

Fig. 7. Activating electrostimulation effects on the initially elevated EEG parameters

The last pattern (Fig. 8) included parameters of the EEG, whose initial normal levels, judging by the mean values, did not significantly change under the influence of electrostimulation. The reason for taking them to consideration will be discussed later.

And now we suggest looking at Figure 9, which shows integrated patterns. The first pattern combines the parameters shown in Figure 5 and displays a normalizing increase in the lowered parameters. Instead, the second pattern reflects the further decrease of the initially lower parameters shown in Figure 6. The third pattern visualizes the irregularity of the initially normal parameters placed on Figure 8. The fourth pattern reflects the normalizing decline of the initially elevated SPD of beta-rhythm in locus O2. The fifth pattern demonstrates the further increase of the initially elevated parameters given in Figure 7.

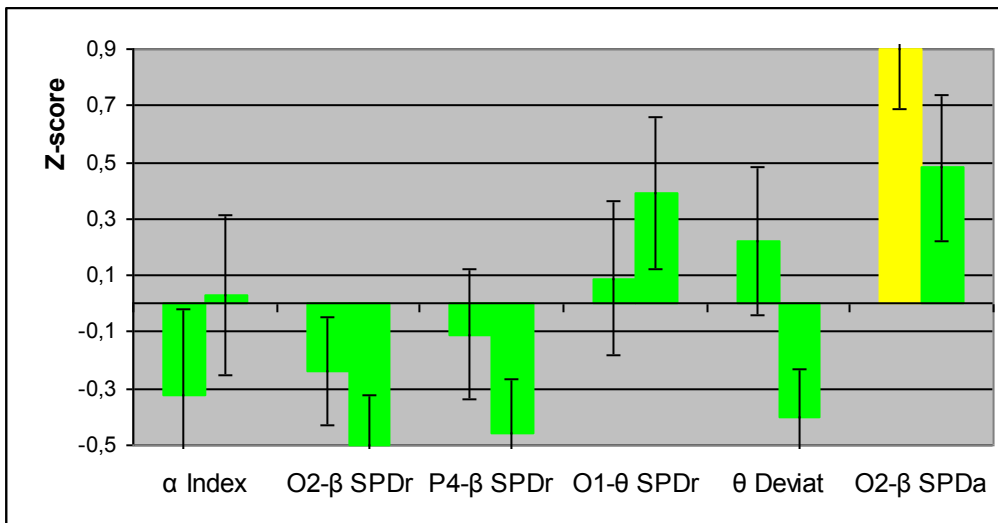

Fig. 8. Uncertain electrostimulation effects on the initially norm EEG parameters

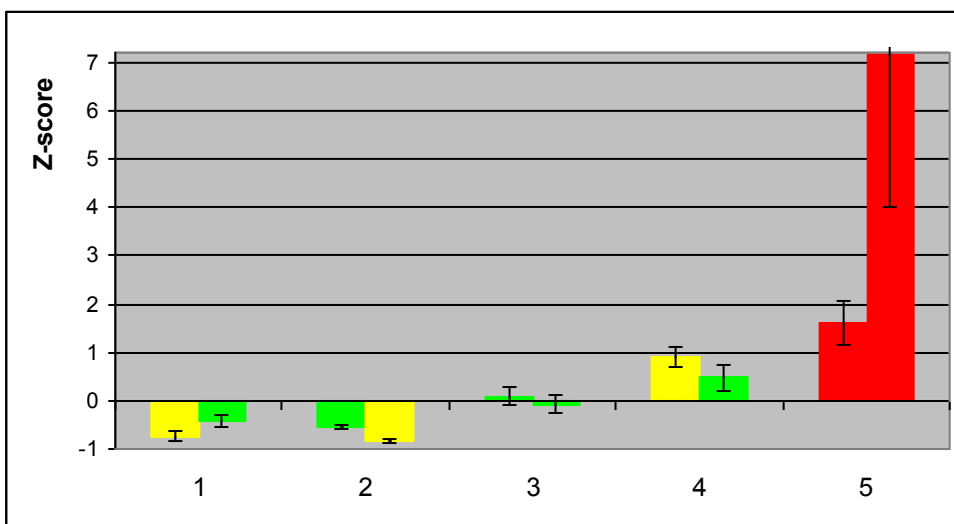

Fig. 9. Integrated patterns of electrostimulation effects on EEG

As we see, only the first, third and fourth patterns correspond to the classical JF Wilder’s “law of the initial level”. However, going ahead, we note that the second and fifth patterns also reflect physiologically favorable changes in the EEG.

If we calculate the changes of the considered parameters of EEG by the method of direct differences, then they are significant for all, including initially normal (Fig. 10-12).

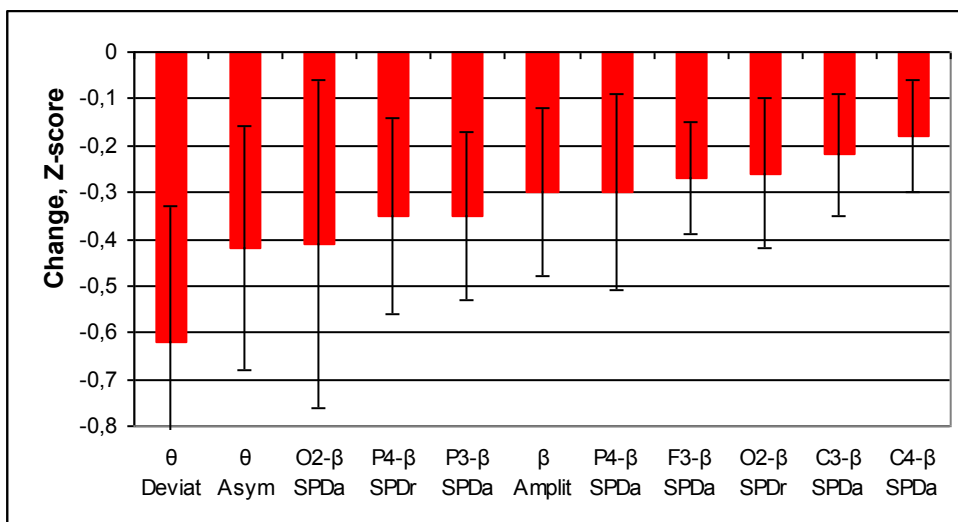

Fig. 10. Ranking of inhibiting neurotropic effects of electrostimulation

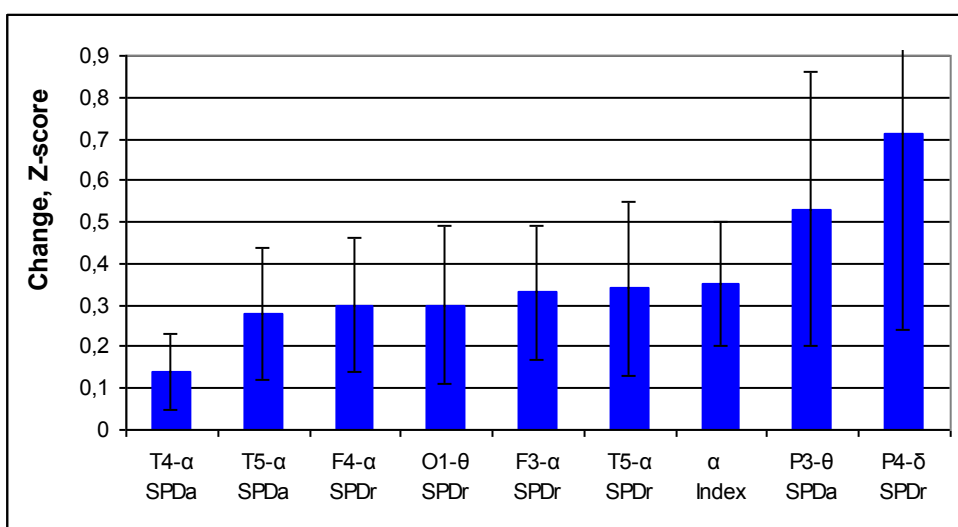

Fig. 11. Ranking of enhancing neurotropic effects of electrostimulation

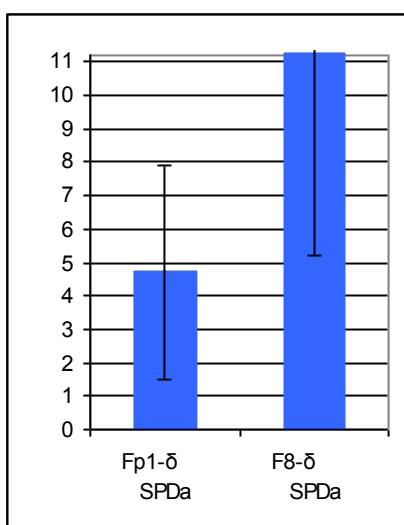

Fig. 12. Drastically enhancing neurotropic effects of electrostimulation

Based on the results of discriminant analysis [7] by the method of forward stepwise the model included 20 parameters EEG (Table 2 and 3).

Table 2. Discriminant Function Analysis Summary

Step 20, N of vars in model: 20; Grouping: 2 grps. Wilks' Λ : 0,020; approx. $F_{(21)}=16,7$; $p<10^{-3}$

Variables currently in the model	Reference level (n=88)	Initial level (n=14)	Final level (n=14)	Change after 4 Seances	Wilks' Λ	Partial Λ	F-remove	p-level	Tolerance
θ -rhythm Deviation, Hz	1,06±0,07 0	1,21±0,18 +0,22±0,26	0,79±0,11 -0,40±0,17	-0,43±0,20 -0,62±0,29	,134	,153	38,8	10 ⁻⁴	,072
F3- β SPD, $\mu V^2/Hz$	89±5 0	59±7 -0,61±0,15	45±4 -0,88±0,08	-13±6 -0,27±0,12	,052	,391	10,9	,013	,088
β -rhythm Amplitude, μV	13,6±0,5 0	11,6±0,7 -0,48±0,17	10,3±0,5 -0,79±0,12	-1,3±0,8 -0,30±0,18	,107	,191	29,6	,001	,017
O2- β SPD, $\mu V^2/Hz$	117±8 0	97±20 -0,27±0,28	66±9 -0,69±0,12	-31±19 -0,42±0,26	,147	,140	43,1	10 ⁻⁴	,011
δ -rhythm Asymmetry, %	33±3 0	57±6 +0,90±0,21	46±7 +0,48±0,26	-11±9 -0,41±0,35	,178	,115	54,0	10 ⁻⁴	,033
C3- β SPD, $\mu V^2/Hz$	96±5 0	62±8 -0,70±0,16	51±4 -0,92±0,08	-11±6 -0,22±0,13	,035	,581	5,0	,060	,066
P4- β SPD, %	25,5±1,8 0	24±4 -0,11±0,23	18±3 -0,46±0,19	-5,8±3,5 -0,35±0,21	,026	,791	1,9	,215	,089
P4- β SPD, $\mu V^2/Hz$	90±4 0	66±8 -0,63±0,21	54±7 -0,93±0,17	-12±8 -0,30±0,21	,040	,514	6,6	,037	,015
O2- β SPD, %	26±2 0	21±4 -0,24±0,19	16±4 -0,50±0,18	-5,2±3,1 -0,26±0,16	,042	,486	7,4	,030	,107
C4- β SPD, $\mu V^2/Hz$	88±5 0	66±8 -0,53±0,20	58±6 -0,71±0,16	-8±5 -0,18±0,12	,102	,200	28,0	,001	,025
F8- δ SPD, $\mu V^2/Hz$	71±14 0	252±106 +1,38±0,81	1730±831 +12,61±6,3	+1478±790 +11,23±6,0	,062	,328	14,3	,007	,016
P3- θ SPD, %	7,6±0,3 0	6,1±0,9 -0,53±0,32	7,6±0,8 0,00±0,28	+1,5±0,9 +0,53±0,33	,223	,092	69,3	10 ⁻⁴	,022
Fp1- δ SPD, $\mu V^2/Hz$	63±13 0	358±146 +2,51±1,25	910±449 +7,23±3,83	+552±374 +4,71±3,19	,088	,232	23,2	,002	,013
P4- δ PSD, %	19,1±1,3 0	31±5 +0,98±0,43	40±7 +1,69±0,53	+9±6 +0,71±0,47	,065	,313	15,4	,006	,023
T5- α SPD, %	37±2 0	22±4 -0,69±0,19	29±6 -0,35±0,27	+7±4 +0,34±0,21	,026	,775	2,0	,197	,079
T5- α SPD, $\mu V^2/Hz$	134±16 0	69±25 -0,43±0,16	112±39 -0,14±0,26	+43±25 +0,28±0,16	,169	,121	50,8	10 ⁻⁴	,010
T4- α SPD, $\mu V^2/Hz$	134±13 0	42±8 -0,75±0,06	59±16 -0,61±0,13	+17±11 +0,14±0,09	,063	,327	14,4	,007	,017
F4- α SPD, %	41±2 0	20±4 -1,07±0,19	26±5 -0,77±0,29	+6±3 +0,30±0,16	,085	,241	22,1	,002	,017
O1- θ SPD, %	5,27±0,34 0	5,55±0,85 +0,09±0,27	6,49±0,85 +0,39±0,27	+0,95±0,60 +0,30±0,19	,027	,768	2,1	,189	,190
O1- α SPD, %	48±3 0	28±7 -0,77±0,26	33±7 -0,58±0,28	+4,9±2,5 +0,19±0,10	,047	,434	9,1	,019	,023

Variables currently not in the model	Reference level (n=88)	Initial level (n=14)	Final level (n=14)	Change after 4 Seances	Wilks' Λ	Partial Λ	F to enter	p-level	Tolerance
P3- β SPD, $\mu V^2/Hz$	100±5 0	74±11 -0,54±0,23	57±6 -0,89±0,12	-17,1±8,6 -0,35±0,18	,020	1,0	,00	,99	,040
α -rhythm Index, %	50±3 0	40±9 -0,32±0,30	51±9 +0,03±0,28	+11±5 +0,35±0,15	,020	,992	,05	,83	,014
F3- α SPD, %	42±2 0	23±4 -0,97±0,22	29±6 -0,63±0,31	+6,5±3,1 +0,33±0,16	,020	,983	,08	,78	,039

Table 3. Summary of Stepwise Analysis

Variables currently in the model	F to enter	p-level	Λ	F-value	p-level
θ -rhythm Deviation, Hz	4,1	,054	,865	4,1	,054
F3- β SPD, $\mu V^2/Hz$	6,0	,022	,698	5,4	,011
F8- δ SPD, $\mu V^2/Hz$	3,5	,074	,610	5,1	,007
P3- θ SPD, %	3,4	,077	,530	5,1	,004
T5- α SPD, %	1,9	,185	,489	4,6	,005
δ -rhythm Asymmetry, %	2,2	,156	,443	4,4	,005
P4- δ PSD, %	3,6	,071	,375	4,8	,003
O2- β SPD, $\mu V^2/Hz$	4,1	,058	,309	5,3	,001
Fp1- δ SPD, $\mu V^2/Hz$	1,7	,204	,282	5,1	,002
β -rhythm Amplitude, μV	2,8	,114	,242	5,3	,001
T5- α SPD, $\mu V^2/Hz$	2,2	,157	,213	5,4	,001
C4- β SPD, $\mu V^2/Hz$	3,0	,106	,178	5,8	,001
C3- β SPD, $\mu V^2/Hz$	1,8	,197	,157	5,8	,001
O1- α SPD, %	2,0	,182	,136	5,9	,001
O2- β SPD, %	5,0	,045	,096	7,5	,0006
F4- α SPD, %	3,6	,083	,072	8,8	,0004
T4- α SPD, $\mu V^2/Hz$	6,5	,029	,044	12,8	,0001
P4- β SPD, $\mu V^2/Hz$	3,6	,090	,031	15,4	,0001
O1- θ SPD, %	1,7	,229	,026	15,8	,0002
P4- β SPD, %	1,9	,216	,020	16,7	,0004

Information about the parameters is condensed in the canonical discriminant root, which correlates with some of them **positively**, and with others **negatively** (Table 4). The same table shows the Raw Coefficients and Constant for discriminant variables, based on which as well as on the individual values of the parameters of the EEG, the individual values of the canonical root before and after electrostimulation course were calculated (Fig. 13).

Table 4. Standardized, Structural and Raw Coefficients and Constant for variables

Variables currently in the model	Standardized	Structural	Raw
F8- δ SPD, $\mu V^2/Hz$	-6,539	,050	-,003
P3- θ SPD, %	6,510	,036	2,011
Fp1- δ SPD, $\mu V^2/Hz$	7,778	,033	,006
P4- δ PSD, %	5,472	,029	,240
T5- α SPD, %	1,710	,029	,090
T5- α SPD, $\mu V^2/Hz$	9,432	,026	,076
T4- α SPD, $\mu V^2/Hz$	-6,276	,027	-,132
F4- α SPD, %	6,676	,025	,383
O1- θ SPD, %	1,118	,022	,351
O1- α SPD, %	-4,994	,014	-,190
θ -rhythm Deviation, Hz	-3,458	-,057	-6,153
F3- β SPD, $\mu V^2/Hz$	-2,660	-,045	-,121
β -rhythm Amplitude, μV	7,003	-,042	3,010
O2- β SPD, $\mu V^2/Hz$	-9,131	-,040	-,156
δ -rhythm Asymmetry, %	-5,209	-,035	-,217
C3- β SPD, $\mu V^2/Hz$	2,541	-,034	,109
P4- β SPD, %	1,546	-,033	,119
P4- β SPD, $\mu V^2/Hz$	5,713	-,031	,205
O2- β SPD, %	-2,218	-,028	-,161
C4- β SPD, $\mu V^2/Hz$	-5,664	-,020	-,201
Eigenvalue	47,856	Constant	-33,1
R=0,990; Wilks' $\Lambda=0,020$; $\chi^2_{(20)}=62$; $p<10^{-5}$			

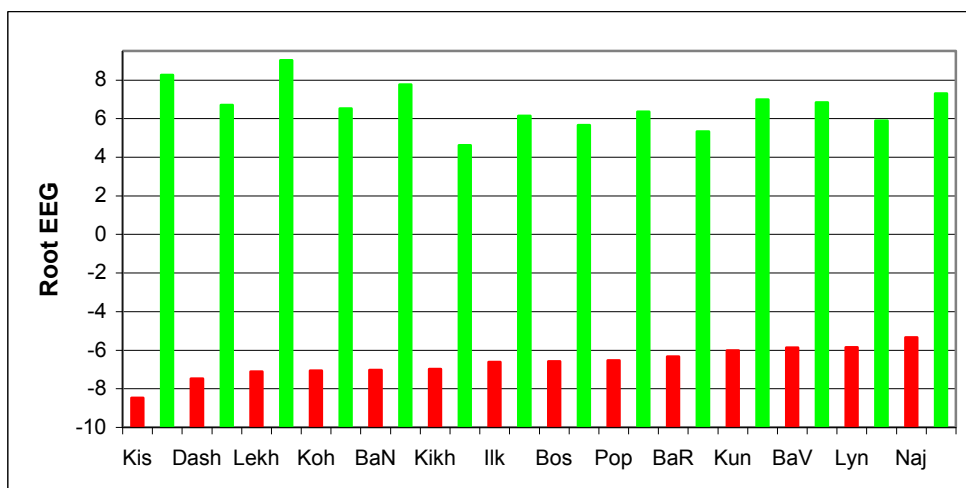

Fig. 13. Individual values of the canonical discriminant root before (red columns) and after (green columns) four-day electrostimulation course with the device "VEB-1"

The striking changes in neurodynamics are documented by calculating the square of the Mahalanobis distance between the recognition parameters before and after the course of electrostimulation: $D^2_M=191$ ($F=16,7$; $p<10^{-3}$).

Selected 20 parameters can be used to identify initial or final status a particular volunteer. This is achieved through the calculation of classification functions on the basis of the obtained Coefficients and Constants (Table 5).

Table 5. Coefficients and Constants for Classification Functions

Variables currently in the model	Before course	After course
θ -rhythm Deviation, Hz	-155,2	-237,2
F3- β SPD, $\mu V^2/Hz$	-2,812	-4,429
F8- δ SPD, $\mu V^2/Hz$	-,095	-,135
P3- θ SPD, %	57,12	83,93
T5- α SPD, %	1,558	2,762
δ -rhythm Asymmetry, %	-5,407	-8,297
P4- δ PSD, %	8,279	11,48
O2- β SPD, $\mu V^2/Hz$	-4,536	-6,610
Fp1- δ SPD, $\mu V^2/Hz$,190	,273
β -rhythm Amplitude, μV	84,36	124,5
T5- α SPD, $\mu V^2/Hz$	2,233	3,251
C4- β SPD, $\mu V^2/Hz$	-5,342	-8,024
C3- β SPD, $\mu V^2/Hz$	2,357	3,808
O1- α SPD, %	-3,298	-5,829
O2- β SPD, %	-4,693	-6,835
F4- α SPD, %	10,75	15,85
T4- α SPD, $\mu V^2/Hz$	-3,820	-5,584
P4- β SPD, $\mu V^2/Hz$	6,549	9,279
O1- θ SPD, %	14,12	18,80
P4- β SPD, %	5,916	7,502
Constants	-511,4	-952,7

In the following articles we will give data on the influence of electrostimulation on parameters of autonomous and hormonal regulation, metabolism as well as gas discharge visualization. After that, there will be a detailed discussion.

ACKNOWLEDGMENT

We express sincere gratitude to administration JSC “Truskavets’kurort” for help in recording EEG. Special thanks to the volunteers.

ACCORDANCE TO ETHICS STANDARDS

Tests in volunteers are conducted in accordance with positions of Helsinki Declaration 1975, revised and complemented in 2002, and directive of National Committee on ethics of scientific researches. During realization of tests from all participants the informed consent is got and used all measures for providing of anonymity of participants.

REFERENCES

1. Babelyuk NV, Babelyuk VYe, Dubkova GI, Kikhtan VV, Musiyenko VY, Hubyts’kyi VY, Dobrovol’s’kyi YG, Korsuns’kyi IH, Kovbasnyuk MM, Korolyshyn TA, Popovych IL. Influence of the course of electrostimulation by the device "ES-01.9 WEB" on some functional systems of the organism of practically healthy men [in Ukrainian]. In: Proceedings VIII Scientific Conference "Issues of pathology in conditions of extreme factors action on the body" (Ternopil’, 1-2 October 2015). Ternopil’. 2015: 5-6.
2. Babelyuk NV, Babelyuk VYe, Dubkova GI, Korolyshyn TA, Kikhtan VV, Dobrovol’s’kyi YG, Korsuns’kyi IH, Kovbasnyuk MM. Electrical stimulation with the device "ES-01.9 WEB" activates some functional systems of the body of practically healthy men [in Ukrainian]. In: Valeology: current status, trends and perspectives of development. Abstracts. XIV Intern. scient. and practical. conf. (Kharkiv-Drohobych, 14-16 April 2016). Kharkiv: VN Karazin KhNU. 2016: 198-200.
3. Babelyuk NV, Babelyuk VYe, Dubkova GI, Kikhtan VV, Musiyenko VY, Hubyts’kyi VY, Dobrovol’s’kyi YG, Korsuns’kyi IH, Kovbasnyuk MM, Korolyshyn TA, Popovych IL. Modulation of functional systems of practically healthy men by the course of electrostimulation [in Ukrainian]. In: IX International symposium “Actual problems of biophysical medicine” (Kyiv, 12-15 May 2016). Kyiv: OO Bohomolets’ Institute of Physiology; 2016: 10-11.
4. Babeluk VE. The patent of Ukraine for utility model 105875 Portable device for electrotherapy and stimulation, 2016.
5. Babelyuk VY, Dobrovolskiy YyG, Popovych IL, Korsunskiy IG. Generator for electrotherapy and stimulation oh human nerve centers [in Russian]. Tekhnologiya i Konstruirovaniye v Elektronnoy Apparature. 2017; 1-2: 23-27.
6. Gozhenko AI, Sydoruk NO, Babelyuk VYe, Dubkova GI, Flyunt VR, Hubyts’kyi VYo, Zukow W, Barylyak LG, Popovych IL. Modulating effects of bioactive water Naftussya from layers Truskavets’ and Pomyarky on some metabolic and biophysic parameters at humans with dysfunction of neuro-endocrine-immune complex. Journal of Education, Health and Sport. 2016; 6(12): 826-842.
7. Klecka WR. Discriminant Analysis [trans. from English in Russian] (Seventh Printing, 1986). In: Factor, Discriminant and Cluster Analysis. Moskwa: Finansy i Statistika. 1989: 78-138.