

Wędrowski Mateusz, Waśniowski Paweł, Wędrowska Ewelina, Piskorska Elżbieta, Czuczejko Jolanta, Malkowski Bogdan, Zukow Walery. Synthesis and application of (¹⁸F) fluorodeoxyglucose in oncology diagnosis. Journal of Education, Health and Sport. 2017;7(12):481-500. eISSN 2391-8306. DOI <http://dx.doi.org/10.5281/zenodo.1164181>
<http://ojs.ukw.edu.pl/index.php/johs/article/view/5245>

The journal has had 7 points in Ministry of Science and Higher Education parametric evaluation. Part B item 1223 (26.01.2017).

1223 Journal of Education, Health and Sport eISSN 2391-8306 7

© The Authors 2017;

This article is published with open access at Licensee Open Journal Systems of Kazimierz Wielki University in Bydgoszcz, Poland

Open Access. This article is distributed under the terms of the Creative Commons Attribution Noncommercial License which permits any noncommercial use, distribution, and reproduction in any medium, provided the original author(s) and source are credited. This is an open access article licensed under the terms of the Creative Commons Attribution Non Commercial License (<http://creativecommons.org/licenses/by-nc/4.0/>) which permits unrestricted, non commercial use, distribution and reproduction in any medium, provided the work is properly cited.

This is an open access article licensed under the terms of the Creative Commons Attribution Non Commercial License (<http://creativecommons.org/licenses/by-nc/4.0/>) which permits unrestricted, non commercial

use, distribution and reproduction in any medium, provided the work is properly cited.

The authors declare that there is no conflict of interests regarding the publication of this paper.

Received: 02.12.2017. Revised: 15.12.2017. Accepted: 31.12.2017.

Synthesis and application of (¹⁸F) fluorodeoxyglucose in oncology diagnosis

Mateusz Wędrowski^{1,2}, Paweł Waśniowski^{3,2}, Ewelina Wędrowska⁴,
Elżbieta Piskorska⁵, Jolanta Czuczejko², Bogdan Małkowski^{1,2}, Walery Zukow⁶

¹Department of Positron Emission Tomography and Molecular Diagnostics, Nicolaus Copernicus University Collegium Medicum, Bydgoszcz, Poland

²Nuclear Medicine Department, Oncology Centre, Bydgoszcz, Poland

³Department of Inorganic and Analytical Chemistry, Nicolaus Copernicus University Collegium Medicum, Bydgoszcz, Poland

⁴Department of Gene Therapy, Faculty of Medicine, Nicolaus Copernicus University
Collegium Medicum, Bydgoszcz, Poland

⁵Department of Pathobiochemistry and Clinical Chemistry, Nicolaus Copernicus
University Collegium Medicum, Bydgoszcz, Poland

⁶Faculty of Earth Sciences, Nicolaus Copernicus University, Toruń, Poland

Corresponding author:

Ewelina Wędrowska

Zakład Genoterapii Collegium Medicum UMK

85-094 Bydgoszcz, ul. M. Skłodowskiej-Curie 9

tel. +48 517-545-893

e-mail: ewelina.wedrowska@gmail.com

Abstract

[¹⁸F] Fluorodeoxyglucose ([¹⁸F] FDG) is the most commonly used radiopharmaceutical in clinical positron emission tomography (PET) in oncology. Cancer cells create their own specific microenvironment to survive and grow. Specific tumor microenvironment contributes to cancer metabolic reprogramming. Therefore,

even with sufficient oxygen availability, cancer cells choose anaerobic glycolysis. Cancer cells compensate less energy efficient process by increasing the intensity of anaerobic glycolysis. Tumor cells have a high rate of metabolism and because of this, they take up more of the radioactive glucose (FDG). This makes the tumor cells appear more visible than other areas on the PET scan pictures.

This paper presents nucleophilic synthesis of the [^{18}F] FDG marker and basics of tumor development which can affect the [^{18}F] FDG biochemical significance. Reference was made to clinical images obtained in PET technology using the [^{18}F] FDG radiopharmaceutical.

Key words: synthesis [^{18}F] FDG, glucose metabolism, [^{18}F] FDG metabolism, positron emission tomography.

Introduction

The radiopharmaceutical consists of two basic parts, a carrier and an isotope. The carrier is a biologically active chemical compound involved in important biochemical processes, and the short-lived isotope is a positron emitter. Its task is to generate a signal that will be recorded by external detectors. The vehicle is labeled by placing a radioactive isotope molecule in its structure.

In the case of [^{18}F] fluorodeoxyglucose, [^{18}F] FDG, the carrier is a 2-deoxy-D-glucose molecule, and the radioactive isotope placed in its structure is fluorine [^{18}F].

[¹⁸F] FDG is the most widely used radiopharmaceutical in the diagnosis of PET, showing various types of tumors characterized by increased glucose metabolism. The widespread use and commercialization of the [¹⁸F] FDG radiotracer contributed to the development of high-throughput synthesis methods, carried out using automated radiochemical modules [1,2].

The half-life of ¹⁸F isotope used for the production of [¹⁸F] Fluorodeoxyglucose is 110 minutes. It is long enough from the point of view of proper marker preparation and performance of the test procedure. The advantageous feature of the ¹⁸F isotope is the access to efficient cyclotron production that gives the possibility of obtaining the isotope in large quantities. In addition, ¹⁸F is characterized by high chemical reactivity and in chemical reactions it can be both a donor (nucleophile) and an electron acceptor (electrophile) [3].

Purpose of work

The aim of this study is to present nucleophilic synthesis of the [¹⁸F]FDG marker and basics of tumor development which can affect the [¹⁸F]FDG biochemical significance. The reference was made to clinical images obtained in PET technology using the [¹⁸F] FDG radiopharmaceutical.

Description of knowledge

Physical aspects of imaging techniques using properties of radiopharmaceuticals.

Positron emission tomography is a emission method using positron emission tomography using [¹⁸F] FDG (PET). In contrast to the absorption methods, in the PET method, the image is generated on the basis of information sent from the object, which requires placing the source of this information in the tested object. The carrier of information in the PET technique is the quantum of gamma radiation, while the source of emitted radiation is the radiopharmaceutical collected in the body.

PET technology is based on the use of isotopes being positronium emitters. The proton p in the nucleus of the isotope degrades β^+ ($p \rightarrow n + e^+ + \nu_e + Energy$), in the radiopharmaceutical molecule, as a result of which neutron n is formed in the nucleus and electron neutrinos ν_e and positronium e^+ emitting electron surplus are emitted from the nucleus. Positronium collisions with electrons is the center, staying a little way up to the loss of most of their energy. In the next step, he annihilates with the electron turning his mass into energy emitted in the form of two gamma quanta, 511 keV each, in opposite directions. Annihilation is the basis on which PET technology is based (Fig. 1) [1].

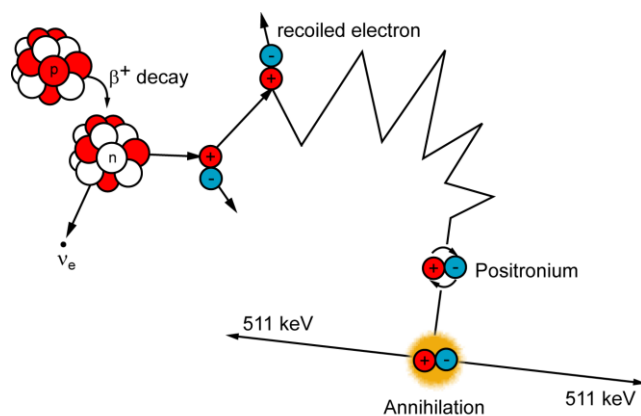

Fig. 1. The scheme of positronium decay and annihilation

If two scintillation detectors from the detector ring in a PET scanner, register a pulse in the same time window, so-called the coincidence window, we can assume that the line of annihilation has taken place between the two detectors and the radiopharmaceutical molecule must be there. This line is called the LOR (line of response) event line. The intersection of these roads indicates a greater concentration of the marker and is the basis for the reconstruction of images in PET diagnostics. The electronic coincidence allows direct determination of the direction from which information comes, so there is no need for additional collimators. Due to this, the sensitivity of the PET scanner is better than in the gamma cameras. In the case of pathological changes, the marker accumulates in a given process or place in the body, which gives the possibility of imaging at the tissue level. In that manner, PET technology allows to recognize pathological changes in their initial stages, the fastest among diagnostic imaging methods. This happens because biochemical changes are ahead of structural changes. However, the limited spatial resolution of PET images

reduces the amount of anatomical information. For this reason, at present, PET technology is most often fused with another medical imaging method that gives more structural information [4].

Other CT imaging methods include CT and MR. CT (computed tomography) is a diagnostic method using X-rays to obtain anatomical images containing information about the structure of organs and tissues. The fusion of PET and CT methods allows for more precise localization of the disease focus in the patient's body [5, 6]. Currently, among modern diagnostic solutions, fusion of PET and MR (magnetic resonance) methods is now available for patients. MR uses the properties of protons from the nuclei of hydrogen atoms in our body in the form of water molecules. Dipole water molecules containing hydrogen protons in their composition, in a strong magnetic field, magnetize, but after removing the field they return to the "balance" by sending radio waves that are registered by the detectors and based on them determines the density of the tested object as the basis for image reconstruction. One of the purposes of combining these two techniques is to obtain structural information of the object being imaged, similar to the case of PET / CT fusion. The advantage of PET / MR is, among others, on better imaging performance of soft tissues without additional exposure to ionizing radiation that occurs in CT [6,7].

Synthesis of [^{18}F] fluorodeoxyglucose using nucleophilic fluorination

Cyclotron production of radioactive ^{18}F isotope

This multistage process begins with the production of negatively charged hydrogen ions H-emitted from the ion source in the cyclotron. The ion source is supplied with hydrogen gas, which undergoes ionization due to the high potential between the cathode and the anode. Ionized hydrogen forms a plasma from which

negative ions are emitted into the accelerating region. These ions are introduced between the cyclotron electrodes of the so-called duant. Initially, the electric potential of the duant is positive in order to attract a negatively charged hydrogen ion, when the ion reaches the edge of the duant, the voltage potential changes to negative. The electric field is responsible for accelerating the ion beam, thus increasing their energy. The applied magnetic field curves the trajectory of charged particles directing them on a spiral trajectory in a cyclotron. Acceleration must take place in the vacuum chamber so that the particle does not lose energy during collisions, too low a vacuum could be a source of additional radionuclides. Ions H-obtained energy 11 MeV (energy of ejection), are directed to carbon film, which deprives hydrogen anions of two electrons. Depending on the model of the cyclotron, an inverting force with an inverted direction acts on the electrically modified H + particles, directing the ions to the cyclotron discs. The discs are made of chemically inert metals, i.e. titanium, niobium, tantalum. The disc substance is water enriched with oxygen isotope [18O] H₂O. The nuclear reaction used to obtain ¹⁸F is ¹⁸O(p,n) ¹⁸F [8,9,10].

Uptake, purification and release of radioactive ¹⁸F isotope

The ¹⁸F ion produced is in an aqueous solution. It is associated with a positively charged particle, a metal cation from the cyclotron target. In addition to the metal cation, water also lowers fluoride ion activity by forming hydrogen bonds with it. In the further stages of the synthesis, remove water together with metal cations from the reaction environment.

In order to separate ¹⁸F⁻ ion impurities to lower its activity fluoride solution and water is passed through an ion exchange column. The most commonly used column is QMA Sep - Pak light, which is filled with an organic polymer connected to

hydrocarbon chains containing at their ends - NR₃⁺ groups derived from quaternary ammonium salts. This group gives the ends of the hydrocarbon chain a positive charge. The counterion counterbalancing the positive charge of the end of the hydrocarbon chain are carbonate anions CO₃²⁻ [11].

Anion exchange takes place on the column, fluoride is retained on the column's deposits, and water along with metal ions and CO₃²⁻ groups flows to the reclaimed water vessel [12].

The next step is to recover the fluoride anion from the QMA Sep - Pak light column by elution using the water - acetonitrile solution of Kryptofix (Kryptand 222) and K₂CO₃. Cryptands are organic compounds obtained synthetically, capable of forming complexes due to the structural matching of the metal cation to the cavity of the macrocycle system. In addition, they have the ability to transfer ions from the aqueous phase to the organic so-called the catalysis of interfacial transfer, desired in this type of reaction [13,14].

Kryptofix binds in its structure - the recess, the K⁺ cation derived from potassium carbonate. The potassium cation becomes a counterion to which for ¹⁸F⁻ it has a higher affinity than to the positive ends of the hydrocarbon chain and is thus released from the QMA Sep-Pak light column and goes into the reaction vessel. In the presence of the Kryptofix structure, the K-¹⁸F bond weakens, and the fluoride anion becomes more aggressive and chemically reactive. In addition, the used cryptand transports the F-anion in the form of the K-¹⁸F complex from water to the aprotic solvent, which is acetonitrile [15,16,17].

During the elution, water residues also get into the reaction vessel, which must be removed. The acetonitrile present in the reaction vessel forms an azeotropic mixture with water. Evaporation of acetonitrile under a nitrogen atmosphere occurs at the

same time as evaporation of the rest of the water. In automatic synthesizers this process is repeated several times [12,15,16,17].

Nucleophilic substitution with radioactive fluorine to the precursor

The purified, dried and high-activity fluoride anion is ready for nucleophilic substitution. The most frequently used precursor in the production of [^{18}F] FDG is 1,3,4,6-tetra-O-acetyl-2-O-trifluoromethanesulfonyl- β -D-mannopyranose commonly known as mannose triflate. The precursor used possesses a trifluoromethanesulfonate leaving group at the 2-position (triflate), in position 1,3,4,6 protecting groups - acetyl. During the nucleophilic substitution reaction, the trifluoromethyl group is replaced by the ^{18}F fluorine isotope and the inversion of the spatial system of the C2 sugar substituents is made according to the mechanism of the $\text{S}_{\text{n}}2$ nucleophilic substitution. The marking temperature should be 90 - 100 ° C, and the process should last a maximum of 5 minutes. Only after the fluoridation is completed, the aprotic solvent evaporates, supported by neutral gas [11,18].

Hydrolysis of the intermediate product

The final stage of the synthesis is the removal of protecting groups from the tetraacetyl - [^{18}F] FDG sediment. The reaction takes place with hydrochloric acid at elevated temperature. Hydrolysis can also be carried out with a strong sodium base, the use of which does not require heating the solution, and this process takes place faster [19].

Purification of the final product

The purification of the crude end product is carried out by passing the final product mixture through a series of columns. The cation exchange column removes

the $K^+ / K222$ complexes, the ion delaying column neutralizes the acid, the column with neutral alumina removes unreacted ^{18}F anions, the C18 column removes tetra-acetyl $[^{18}F]$ FDG (Fig. 2) [20].

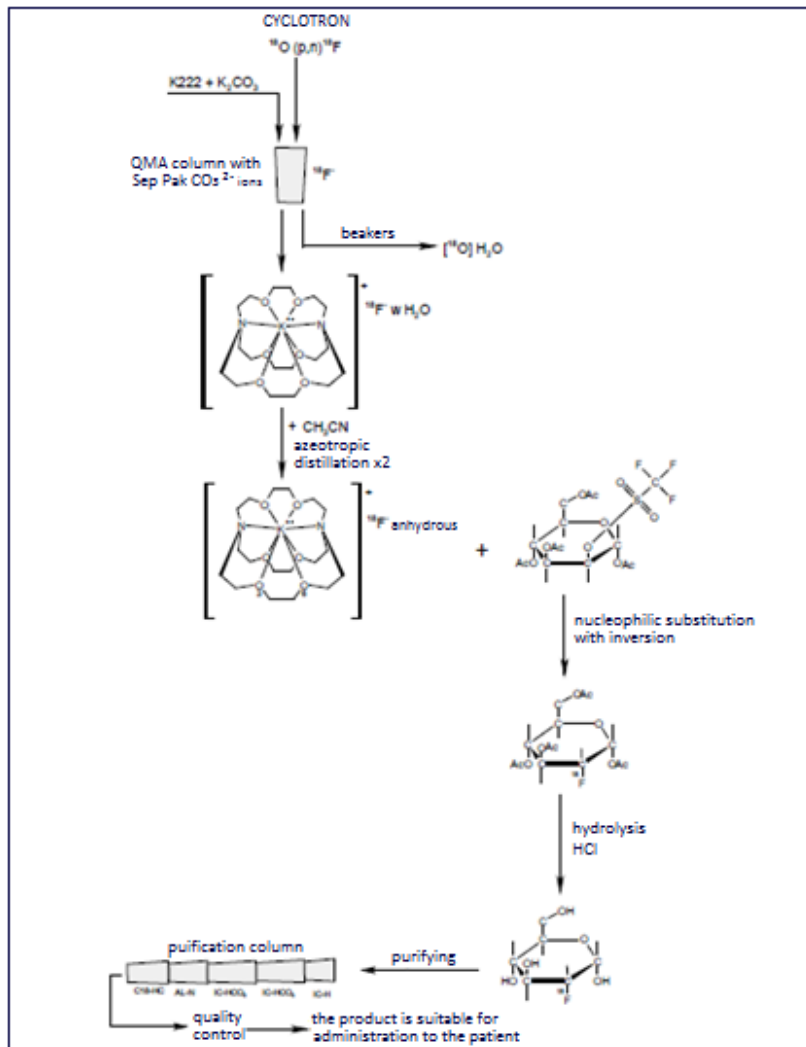

Fig. 2. Synthesis $[^{18}F]$ FDG

Metabolism of glucose and [18F] FDG in cancerous cells

Cancerous cells are characterized by unlimited replication potential, production of their own growth factors, resistance to apoptosis, ability to create their own blood vessel network, inducing inflammation, ignoring signals inhibiting proliferation and different cellular metabolism [21].

Cancerous cells, to survive and grow, create their own specific microenvironment. One of the most important elements of creating such conditions is the ability of the tumor to create its own blood vessel network - angiogenesis. This network participates in supplying cells with nutrients, growth factors, adequate amount of oxygen and removing unnecessary metabolic substances. In physiological as well as tumor angiogenesis, vascular endothelial growth factor (VEGF) plays a major role. The nascent tumor network is significantly different from normal vessels. These are immature vessels with a disordered structure and variable blood flow resulting in cyclical, variable hypoxia. Lack of oxygen activates proangiogenic factors (including VEGF) inducing the formation of consecutive abnormally developed vessels. In this environment, the cancer metabolism is reprogrammed [22,23]. Activation of HIF1 α hypoxia-inducible transcription factor (hypoxia inducible factor 1 α) leads to inhibition of mitochondrial respiration and shifting glucose metabolism towards glycolysis. At the biochemical level, this occurs as a result of the inactivation of pyruvate dehydrogenase by the pyruvate dehydrogenase kinase and leads to a reduction of the conversion of pyruvate to acetyl-CoA. In addition, HIF1 α is responsible for changes in the expression of many genes,

including overexpression of the glucose transporter 1 - GLUT 1 (glucose transporter 1) and enzymes involved in the glycolysis process. All these factors affect the increase in glucose metabolism [24].

Correct cells in the glycolysis process, under conditions of sufficient access to oxygen, metabolize glucose to pyruvate. Then acetyl - CoA formed from the pyruvate oxidation enters the Krebs cycle in which it undergoes oxidation to CO₂ and H₂O. As a result, one mole of glucose provides 30 (or 32) moles of ATP. Under conditions of limited access to oxygen, pyruvate is converted to lactic acid, of which only 2 moles of ATP are formed [25, 26]. Tumor-altered cells, even with sufficient oxygen availability, opt for anaerobic glycolysis, although it provides small amounts of ATP. This is because in the glycolysis process intermediate products are created, needed, among others for the synthesis of nucleic acids, proteins and lipids. Cancerous cells compensate for the choice of a less efficient process by increasing the intensity of anaerobic glycolysis 124 times. Increasing the intensity of this process increases the formation of intermediate products, sustains the supply of energy and nutrients at an appropriate level [21,24,27].

The described tumor feature was used in the diagnosis of tumor focuses using the positron emission tomography method using [¹⁸F] FDG. This compound is transported and metabolized by the same mechanisms as glucose, but there are some differences on the pathway. [¹⁸F] FDG is phosphorylated by hexokinase to 2- [¹⁸F] Fluoro-2-deoxy-glucose-6-phosphate and in this form it accumulates in tumor cells because 2- [¹⁸F] Fluoro-2-deoxy-glucose-6-

phosphate is not further transformed by phosphoglucose isomerase, due to the lack of adaptation of the enzyme to the molecule of this compound. After the ^{18}F radioactive decomposition embedded in the $[^{18}\text{F}]$ FDG molecule, the oxygen formed with ^{18}F combines with the hydrogen molecule to form a group $[^{18}\text{O}]$ -OH at the C2 carbon of glucose. The resulting glucose-6-phosphate is then converted by phosphoglucose isomerase and can undergo further transformation in the glycolysis process (Figure 3) [28].

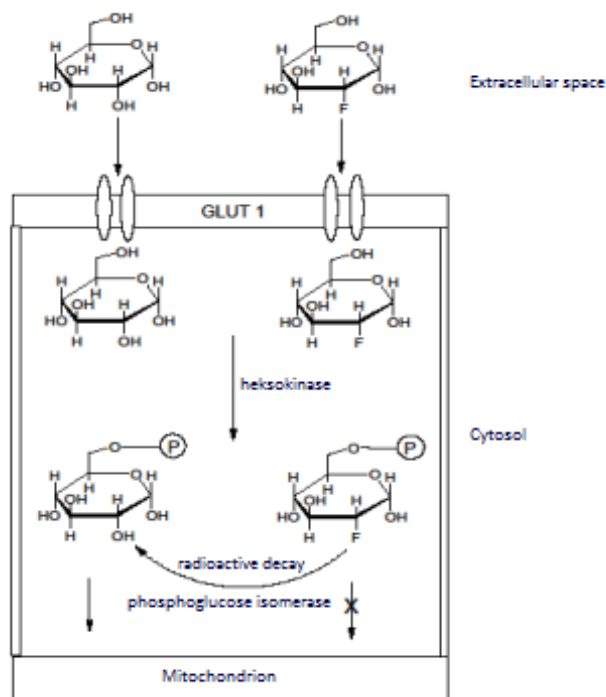

Fig. 3. The mechanism of accumulation $[^{18}\text{F}]$ FDG in a cell - a molecular trap

Tests performed using the described tag

The purified preparation is a sterile colorless liquid which, after dilution with physiological saline, is administered intravenously to the patient for diagnostic purposes. The dose should be in the range of 400 - 700 MBq, in a maximum volume of 5 ml. The preferred techniques for assessing glucose analogue metabolism are PET / CT and PET / MRI. In November 2009, the Committee of the European Society of Nuclear Medicine developed guidelines for the use of PET / CT imaging using [¹⁸F] FDG in the diagnosis of neoplastic diseases [29].

Examination of [¹⁸F] FDG PET / CT has a higher sensitivity than CT scan in the diagnosis of a single nodule lung, staging of lung cancer, staging, control treatment and control the treatment of Hodgkin's lymphoma and lymphomas, non-Hodgkin's lymphoma, staging and diagnosis of recurrence in colorectal cancer, assessment of the severity, treatment control and diagnosis of recurrence of esophageal cancer, assessment of the severity of melanoma, especially in patients with suspected metastases to regional lymph nodes and metastases to distant organs [29].

Medical significance

However, the study using the described analog has some limitations. Too high glucose concentration in the blood of the patient may result in a reduction in [¹⁸F] FDG uptake at lesion sites, via competitive mechanisms. For this reason, patients are required to remain fasting before PET / CT studies using [¹⁸F] FDG. Difficulties arise in the diagnosis of patients with diagnosed diabetes. Specific rules for the preparation of patients included in the guidelines EANM- include, inter alia, maintaining an

appropriate interval from the last administered dose of insulin and oral hypoglycemic agents withdrawal.

Figure 4 shows a scan from a PET / CT study using [^{18}F] FDG in a patient who received metformin on the day of the study - high activity in the gut. Unfortunately, this mark does not work specifically on cancerous processes. Competitive mechanisms are observed in the case of inflammatory processes and infections.



Fig. 4. PET / CT examination using [^{18}F] FDG after taking metformin - high activity in the gut.

Figure 5 shows stimulation in the throat - probably resulting from the ongoing inflammatory process. A significant influence on FDG metabolism has also previous surgery or radiotherapy. However, the clinical situation of the patient does not always allow to maintain an adequate distance between the performed procedures and the PET examination.

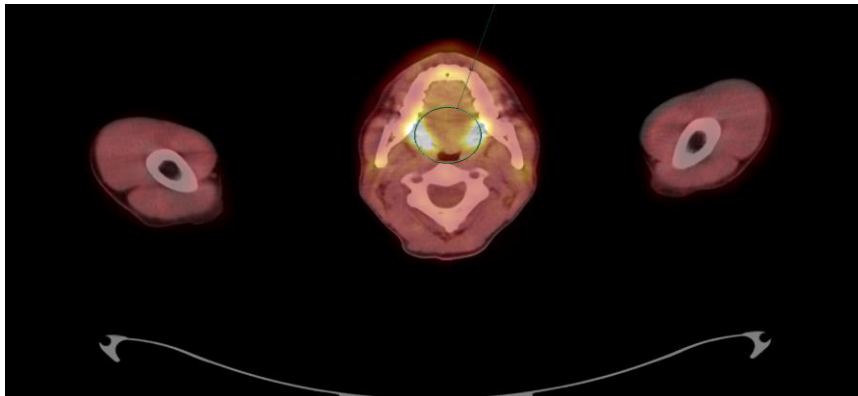

Fig. 5. Throat PET examination using [^{18}F]FDG

Figure 6 shows metabolic stimulation within the uterus resulting from one month before the examination of the cervical conization.

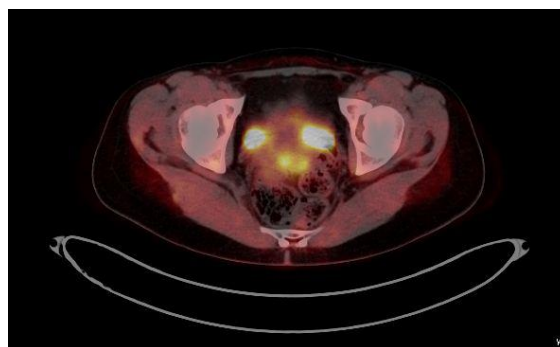

Fig. 6. Uterine PET examination using [^{18}F] FDG

When assessing the PET / CT examination, one should remember first of all about the physiological accumulation of radiopharmaceutical in the heart or liver, as well as due to the secretion in the urine - in the kidneys and bladder - Fig. 7.



Fig. 7. PET/CT examination using [^{18}F] FDG

Summation

Described in this article [^{18}F] FDG due to its versatility and the possibility of obtaining it in large quantities is the most commonly used radiopharmaceutical in the diagnosis of PET. [^{18}F] FDG, however, possesses some drawbacks such as its non-specific uptake. In many cases highly differentiated tumours are difficult to distinguish from inflammation or infection using this radiopharmaceutical. In addition, [^{18}F] FDG has a limited application in imaging tumors in the brain, muscles and bladder. The solution is to use tags specific to a given type of cancer. Currently, Positron Emission Tomography can choose from a large number of radiotracers: [^{11}C] OCTAN - prostate cancer, [^{18}F] DOPA - diagnosis of Parkinson's disease and neuroendocrine tumors, [^{18}F] FET - brain tumors, [^{18}F] FES - estrogen receptors in breast tumors and many others [30]. This should not be a reason to rest on your laurels. The future of Positron Emission Tomography will depend on research into new radiopharmaceuticals. Search should not be limited only

to the discovery of new molecules and attempts to attach a radioactive isotope to them. Researchers should also consider developing new synthesis methods to accelerate them, improve synthesis modules and isotope production equipment.

References

1. Ruangma A. FDG-PET and FDG production at Wattanosoth Hospital. *The Bangkok Medical Journal*. 2013; 5: 80 – 90
2. Królicki L, Kunikowska J, Kobylecka M et al. Znaczenie pozytonowej tomografii emisyjnej (PET) w diagnostyce schorzeń onkologicznych, *Post Nauk Med*. 2011; 2:104 – 108
3. Jacobson O, Kiesewetter DO, Chen X. Fluoride – 18 Radiochemistry, Labeling Strategies and Synthetic Routes. *American Chemical Society* 2015; 26: 1-18
4. Ziegler SI. Positron Emission Tomography: Principles, Technology, and Recent Developments. *Nuclear Physics*, 2005; 679–687
5. Goldman LW. Principles of CT and CT Technology. *J. Nucl. Med. Technol*. 2007; 25, 3: 115-128
6. Vogel WV, Oyen WJG, Barentsz JO et al. PET/CT: Panacea, Redundancy, or Something in Between? *J. Nucl. Med*. 2004; 45: 15-24
7. Gibby WA. Basic principles of magnetic resonance imaging. *Neurosurg Clin N Am*. 2005; 16: 1-64
8. IAEA International Atomic Energy Agency. Cyclotron Produced Radionuclides: Principles and Practice. Technical Reports Series No. 465, Vienna 2008
9. Dewan L. June 2007 Design and Construction of a Cyclotron Capable of Accelerating Protons to 2 MeV. Bachelor of Science in Nuclear Science and Engineering, Massachusetts Institute of Technology, Department of Nuclear Science and Engineering, <http://web.mit.edu/ldewan/Public/22thesis/22thesis10.pdf>
10. Welch MJ, Redvanly CS. Handbook of Radiopharmaceuticals Radiochemistry and applications. The Atrium, Southern Gate, Chichester, West Sussex PO19 8SQ, England, John Wiley & Sons, 2003, ISBN: 0-471-49560-3
11. Schlyer DJ. PET tracers and radiochemistry. *Ann Acad Med. Singapore* 2004; 33(2):146-54.
12. Krasikova R. PET Radiochemistry Automation: State of the Art and Future Trends in ¹⁸F-nucleophilic Fluorination. *Curr. Org. Chem*. 2013; 17: 2097-2107
13. Kołodziej B. Synteza i badanie struktury iminowych podandów, kryptandów, dendrymerów oraz wybranych podatków i kryptatów o potencjalnym zastosowaniu w medycynie i nanotechnologii. 2008; praca doktorska, Politechnika Szczecińska, Katedra Chemii Nieorganicznej i Analitycznej, Zakład Chemii Analitycznej, <http://zbc.ksiaznica.szczecin.pl/dlibra/doccontent?id=2129>
14. Orozbaev B. Dynamika molekularna w ligandach makrocyklicznych typu Podand badana za pomocą Spektroskopii Dielektrycznej i NMR. 2012; praca doktorska, Uniwersytet im. Adama Mickiewicza w Poznaniu, Wydział Fizyki UAM, Zakład Fizyki Makromolekularnej, <https://repozytorium.amu.edu.pl/bitstream/10593/3968/1/Bakyt%20Orozbaev%20%E2%80%93%20Praca%20doktorska.pdf>

15. Yu S. Review of ¹⁸F-FDG synthesis and quality control. *Biomed Imaging Interv J.* 2006; 2(4): 57
16. Cai L, Lu S, Pike VW. Chemistry with [¹⁸F]Fluoride Ion. *Eur. J. Org. Chem.* 2008; 2853–2873
17. Jacobson O, Chen X. PET Designated Fluoride-18 Production and Chemistry. *Curr Top Med Chem.* 2010; 10(11): 1048–1059
18. Osborn NJ, Grigg J, Pettitt RP et al. Fluoridation process for the synthesis of 2 – [¹⁸F] fluoro – 2 – deoxy – D – glucose. 05813632.6,GB, 19.11.2004, international.
19. Saha GB, „Synthesis of PET radiopharmaceuticals. *Basics of PET Imaging, Physics, Chemistry and Regulations.* NY Springer Publishing , 2005:113.
20. Scott PJH, Hockley BG. *Radiochemical Syntheses, Volume 1: Radiopharmaceuticals for Positron Emission Tomography.* John Wiley & Sons, Canada 2011, ISBN 978-0-470-58895-6
21. Malenda A, Nowis DA. Znaczenie metabolizmu glukozy w diagnostyce oraz terapii nowotworów układów krwiotwórczego i chłonnego. *Hematologia* 2013; 4(3): 227–238
22. Szala S. Angiogeneza i immunosupresja: jin i jang progresji nowotworów? *Postępy Hig Med Dosw.* 2009; 63: 598-612
23. Szala S, Jarosz M. Nowotworowe naczynia krwionośne. *Postępy Hig Med Dosw.* 2011; 65: 437-446
24. Józwiak P, Lipińska A. Rola transportera glukozy 1 (GLUT1) w diagnostyce i terapii nowotworów. *Postępy Hig Med Dosw.* 2012; 66: 165-174
25. Ganapathy V, Thangaraju M, Prasad PD. Nutrient transporters in cancer: relevance to Warburg hypothesis and beyond. *Pharmacol. Ther.* 2009; 121: 29–40
26. Ferreira LMR. Cancer metabolism: the Warburg effect today. *Exp. Mol. Pathol.* 2010; 89: 372-380
27. Dudziak K, Regulaska-Ilow B. Znaczenie ładunku glikemicznego diety w rozwoju chorób nowotworowych. *Postępy Hig Med Dosw.* 2013; 67: 449-462
28. Izuishi K, Yamamoto Y, Mori H et al. Molecular mechanisms of [¹⁸F]fluorodeoxyglucose accumulation in liver cancer. *Oncol. Rep.* 2014; 31: 701-706
29. Obwieszczenie Ministra zdrowia z dnia 22 grudnia 2014 r. w sprawie ogłoszenia wykazu wzorcowych procedur radiologicznych z zakresu medycyny nuklearnej (Dz. Urz. Min. Zdrow., poz. 82)
30. Wadsak W, Mitterhauser M. Basics and principles of radiopharmaceuticals for PET/CT. *Eur J Radiol Open.* 2010; 73:461-469