

Modern use of modified Sequencing Batch Reactor in wastewater Treatment

Afzal Hussain Khan¹, Hassan Ahmad Rudayni², Anis Ahmad Chaudhary²,
Mohd Imran³, Sergij Vambol^{4,*}

¹Civil Engineering Department, College of Engineering, Jazan University, P.O. Box. 706, Jazan, 45142, Saudi Arabia

²Department of Biology, College of Science, Imam Mohammad Ibn Saud Islamic University (IMSIU), Riyadh-11623,
Saudi Arabia

³Department of Chemical Engineering, College of Engineering, Jazan University, P.O. Box. 706,
Jazan 45142, Saudi Arabia

⁴Department of Occupational and Environmental Safety, National Technical University “Kharkiv Polytechnic Institute”,
Kharkiv, Ukraine

* corresponding author e-mail: sergvambol@gmail.com

Received: 9 May 2022 / Accepted: 25 May 2022

Abstract. If wastes are not properly managed, it may seep into the earth and aquifers, polluting both the surface and the water table. For public health reasons, leachate is considered a major environmental hazard due to its poisonous and hardy components. Because of this, it must be collected and processed adequately before being released into nature. Currently, there is no single unit procedure for appropriate leachate treatment since traditional wastewater treatment techniques are unable to degrade harmful chemicals contained in the leachate to a suitable level. Consequently, there has been an increase in the study of various leachate treatment procedures in order to maximise operational versatility. Various strategies have been used to degrade the leachate based on its properties, discharge requirements, technological possibilities, regulatory restrictions, and cost concerns. Sequencing batch reactor (SBR) treatment systems for landfill leachate were lauded for their operating flexibility, shock load resilience, and high biomass retention in the interest of long-term sustainability for the environment. Therefore, the current work objective is a deeper study of the features of SBR to identify prospects and unresolved problems in this process. The content analysis method of scientific publications from rating journals indexed in Scopus, PubMed, ScienceDirect, ResearchGate, Google Scholar on the totality of the keywords of this study in various combinations was applied; selection and synthesis of the main characteristics SBR to identify gaps in this area and prospects for future research. An in-depth analysis of the benefits and drawbacks of different leachate degrading processes is provided in this article. The role of integrated leachate treatment technologies with SBR was also highlighted. The effects of various materials, techniques, tactics, and configurations on leachate treatment were also explored in the paper. Critiqued SBR system environmental and operational factors were addressed. Readers of this work are expected to get a better understanding of SBR studies for leachate treatment and to use this information as a guide for their own research in this field. It uses the fill and draw activated sludge system with clarifier and intermittent aeration mode, where all the metabolic reactions and the separation of solid-liquid takes place in a unit tank through a timed control sequence in a non-steady state, variable capacity and suspended growth biological wastewater treatment system. The simultaneous nitrification, denitrification, and phosphorus removal are made possible by combining anaerobic and aerobic processes.

Key words: sequencing batch reactor, pollution, treatment, nitrification, denitrification, biological wastewater treatment.

1. Introduction

1.1 Problem statement

If wastes are not properly managed, it may seep into the earth and aquifers, polluting both the surface and the water table. For public health reasons, leachate is considered a major environmental hazard due of its poisonous and hardy components. Because of this, it must be collected and processed adequately before being released into nature (Vambol et al., 2017; Sakalova et al., 2019; Voytovych et al., 2020; Pochwatka et al., 2020). Conventional biological wastewater treatment processes confront serious hurdles as environmental regulations continue to tighten. The sequencing batch reactor (SBR) technique is a variation of the widely used activated sludge (AS) method (ASP) (Wang et al., 2022). Converting ASP-based treatment processes to batch processes as in SBR can help introduce a wide range of options and flexibility for control and design to better meet the current effluent discharge requirements. In the beginning, the name „SBR” was coined. SBR-like fill and draw procedures, contrary to popular assumption, were widely used between 1914 and 1920 (Khalil & Liu, 2021). Due to advances in aeration and process control technologies in the late 1950s and early 1960s, SBR technology as we know it was revived. Sewage treatment and the treatment of high-strength industrial waste were the primary uses of SBR technology in its early years (Patel et al., 2021). Biological treatment of industrial wastewater containing difficult-to-treat organic compounds has found widespread adoption due to the SBR process’s design flexibility and improved process control made possible by contemporary technologies (Nancharaiha & Kiran Kumar Reddy, 2018). More than 60% of the operational costs of a conventional ASP can be saved by using the SBR process, which is effectively automated and can achieve good effluent quality in a short period. With its low space and staff requirements, SBR is becoming a preferred technology in densely populated countries like India and Europe (Piotrowski et al., 2021). The SBR method is generally favored over the continuous flow process (CFP) because of lower energy consumption and enhanced selective pressures for BOD, nutrient removal, and control of filamentous bacteria (Lee et al., 2010). The SBR process has grown enormously in recent years as a result of these factors. Over the past few years, the SBR technology has undergone a lot of small and large modifications in order to properly treat the ever-increasing number of new pollutants in wastewater.

In an activated sludge process, all of the unit processes are running simultaneously at any given time. As a result of these unit processes taking place consecutively within a single tank in an SBR process, all of these unit processes are carried

out in sequential order over a long period (Karadag et al., 2015). To put it another way, SBR provides a similar level of treatment to the CFP in terms of time. In essence, the SBR technique employs an activated sludge-like fill-and-draw biological wastewater treatment process (Miao et al., 2015a). Single or several tanks can be used with the SBR system and its modifications and hybrids, depending on the scope of the operation, and each tank has five main operating modes: Fill, React, Settle, Draw, and Idle. Each mode in the tank can be changed to fulfil different treatment needs, such as low COD in the effluent or biological nutrient removal, as a batch operation (Jagaba et al., 2021). The various modes of operation for an SBR system are shown schematically in Figure 1.

In addition, the picture reveals a few alternate configurations that can be made throughout each of the individual processes in order to achieve certain therapeutic goals. At this point, a new cycle begins, and the tank receives the raw wastewater that has come into touch with the active biomass that was in the tank at the beginning of the previous cycle (Wang et al., 2018). Due to the fact that SBR has a number of attractive advantages for practical application, the current work objective is to study the features of this wastewater treatment process in more depth in order to identify prospects and unresolved problems in this process. This review work will highlight the need and scope of new generation modification of SBRs.

1.2 Methods

To achieve the goal, the content analysis method of scientific publications from rating journals indexed in Scopus, PubMed, ScienceDirect, ResearchGate, Google Scholar on the totality of the keywords of this study in various combinations was applied; selection and synthesis of the main characteristics SBR to identify gaps in this area and prospects for future research.

After studying the content, the information received was structured using synthesis, generalization and deduction:

- Biological nutrient removal in SBRs,
- Understanding flow condition for specific SBRs,
- Microbial ecology and population dynamics,
- Modification and new forms of SBRs,
- Operation parameter modification and its effects,
- Sequencing Batch Biofilm Reactor.

2. Biological nutrient removal in SBRs’

Depending on the parameters of the wastewater, the target organics, and biological nutrient removal, there are three options: static fill, mixed fill, and aerated fill. Sludge settles better because of a higher food-to-microorganisms (F/M)

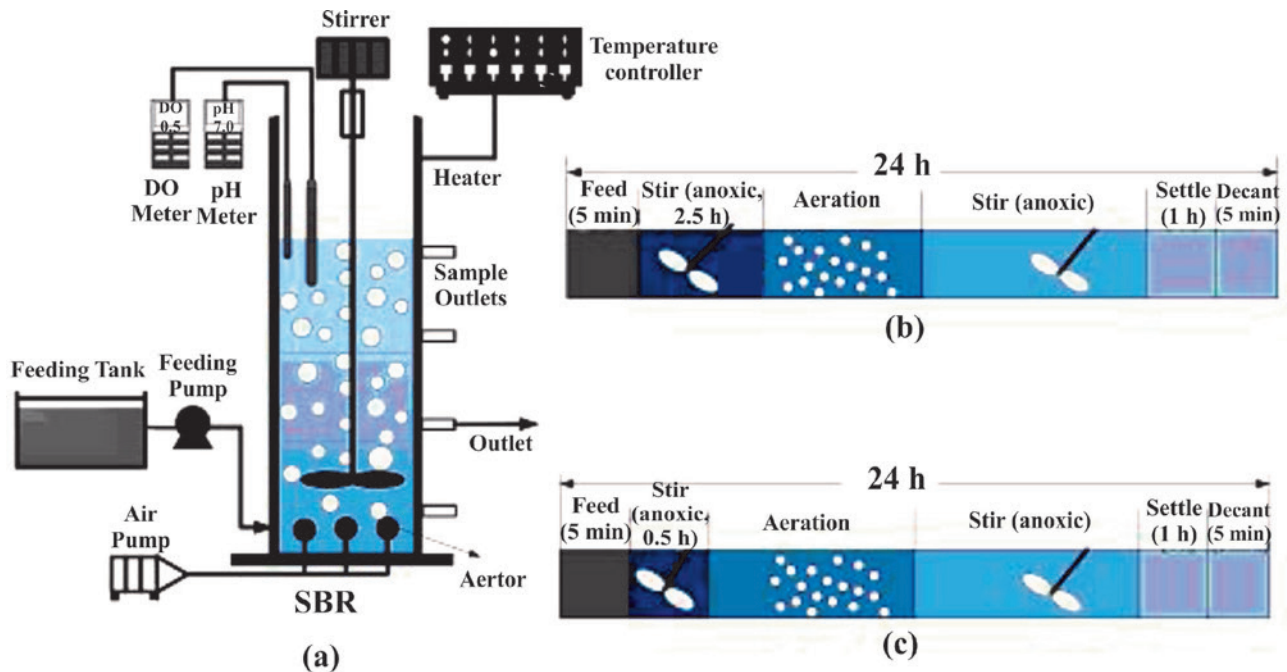

Figure 1. The various modes of operation for an SBR system: (a) Innovative schematic diagram of modified SBR (b) operational steps with three phase cycle and (c) operational steps of the modified SBR with four cycles (Miao et al., 2015a)

ratio created by the static filling of influent wastewater into the SBR, which is comparable to a selection compartment in an ASP (Abdulgader et al., 2020). This method encourages the growth of floc-forming bacteria while inhibiting the filamentous ones. Circumstances in which PAO (phosphate-accumulating organisms) thrive are also created by static fill conditions, as detailed in the section on biological phosphorus removal. Chemical degradation of organic compounds can be completed only when the React phase has taken place. There are many ways to remove nutrients from the water during the React phase. For anaerobic, anoxic, or aerobic effects, the treatment is managed by airflow (Ji et al., 2021). Mixture and aerated reaction modes can be used as alternatives. The aerobic reactions started during aerated fill are finished during aerated respond. It is common for designs to incorporate the nitrification process, which involves converting ammonia nitrogen into nitrite nitrogen and then nitrate nitrogen (Miao et al., 2015b). Other than anoxic and anaerobic settings, the reactor can be mixed react mode in the presence of anoxia. Nitrate-nitrogen can be transformed to nitrogen gas through denitrification under anoxic circumstances (Ding et al., 2021). An anaerobic environment will increase phosphorus elimination by creating a famine phase. At this point, the entire reactor tank is acting as a batch clarifier, with no incoming or egressing water. Due to the constant flow and flow of liquid in CFP processes, the quiescent settling process is typically hindered, resulting in poor effluent quality. As a result of

the settlement of the biomass that was formed during the React phase, an appropriate decanter is used to decant and remove the treated supernatant. Between the drawing and filling phases, the idle phase is the time (Guo et al., 2022). This phase is often required when multiple reactors are operating simultaneously, acting as a buffer in terms of time. Depending on the operating plan, mixing the biomass to condition the reactive contents and wasting superfluous sludge may be taken up during this step.

An SBR system's cycle time includes both Fill and Idle phases for a single tank SBR. Using a sequence of tanks, the multiple tank system makes sure that each tank's Draw is completed before the Fill of the next tank is complete (Ahmad Hussaini Jagaba et al., 2021). With a low population density or changeable flow conditions, a single tank operation is a good fit. In high-yielding multiple tank systems, microorganisms are wasted once per cycle during the response phase; in low-yielding single tank systems, the frequency of waste might be as low as once every two weeks (Barros et al., 2020).

3. Understanding flow condition for specific SBRs

No need for a separate clarifier unit because of the SBR tank's mixing, reacting, and settling capabilities. A CSTR-like or ideal PFR-like treatment characteristic can be achieved by

varying the Fill and React phase time. Significant operational flexibility is provided by the SBR system, such as internal equalization and biological reaction control through adjustment of aeration. When substantial quantities of microorganisms are present in the Fill phase, treatment time is significantly reduced. Controlling nitrogen content and filamentous organism population is made easier by the ability to change aeration length during Fill, which allows for greater flexibility. Nitrogen elimination from the system is facilitated by an anoxic interval during the React phase (Al-Mamun et al., 2020).

The formation of filamentous bacteria with poor settling characteristics in ASP can be attributed to operating conditions such as low dissolved oxygen (DO), low F/M ratio, and totally mixed operation. A condition known as sludge bulking occurs when the effluent contains too many suspended solids, resulting in a decrease in the treatment plant's efficiency (Li et al., 2019). There are several similarities between SBR and ASP processes when it comes to sludge bulking. Bioreactors known as bio-selectors or simply selectors are typically used in the SBR process in order to address this difficulty. They are designed in a way to encourage the development of floc-forming heterotrophic bacteria over filamentous bacteria. When activated sludge is returned to a floc-forming unit, it is mixed with influent wastewater in a separate, initial contact zone known as a selection zone. Molecular oxygen is scarce or absent in the initial contact zone when heterotrophs remove the majority (75–90%) of wastewater's low molecular weight, soluble substrates within the first 5–10 minutes before storing the absorbed food for later use when molecular oxygen is readily available. It's not uncommon for denitrifiers to utilize nitrate or nitrite for their metabolic needs (Bucci et al., 2021). Unlike floc formers, filamentous bacteria cannot store substrate for later use and hence cannot compete with them at high F/M ratios. This means that floc-forming bacteria in the selection zone and the SBR are able to suppress them during future aeration, anoxic conditions and anaerobic phases (Wang et al., 2020). To achieve denitrification and biological phosphorus removal, the selectors can be anoxic or anaerobic by adjusting the mixing degree at low or no oxygen supply. SBR tank aeration must be completed before selectors may work effectively so that the sludge returned to the reactor does not include any unoxidized substrate.

4. Microbial ecology and population dynamics

Environmental variables and the microbial community are referred to as 'ecosystems' because of their interdependent nature. The key environmental aspects in a biological wastewater treatment plant are described by parameters such

as hydraulic retention time, solids retention time or sludge age, substrate, co-substrate, oxygen, pH, temperature, and salinity, as well as other variables. Most of these parameters, like temperature, can be controlled by treatment facilities, but only to a limited extent (Chen et al., 2022; Guo et al., 2022). Chemical engineers are responsible for developing a procedure that can consistently and inexpensively treat wastewater by selecting the best microorganisms for the job. An appropriate biomass structure (e.g. floc or grannie) must be produced by the microbial consortium selected in order to facilitate the separation of the treated emu from the microbial community. To put it another way, the most efficient operation of an activated sludge plant produces a microbial community capable of providing the maximum metabolic activity required to achieve the treatment goals, produces a compact biomass floc without extending filaments, and has a low volume index, which means it is easy to settle out the sludge (SVI) (Hou et al., 2022).

The conversion of soluble and colloidal organic molecules into cellular mass, carbon dioxide, water, and soluble microbial by-products, is usually measured as COD elimination. Nitrification, or the oxidation of ammonia nitrogen into nitrite-nitrogen and nitrate-nitrogen. Denitrification, is the process of converting nitrate-nitrogen to nitrite-nitrogen and then to nitrogen gas. A process known as enhanced biological phosphorus removal (EBPR), sometimes known as „Bio-Phenol removal,” is a way to remove phosphorus from wastewater by using more biomass (i.e., waste-activated sludge). Heterotrophs obtain their energy and carbon from carbon-based molecules (i.e., the electron donor). The removal of COD by aerobic processes is generally rapid, and the final products are typically cell mass, carbon dioxide, and water, frequently with only traces of organic by-products. It is known as 'anoxic' conditions when heterotrophs, rather than using unoxidized forms of nitrogen (nitrate or nitrite), act as electron acceptors during denitrification and create the same final products at lower rates, but with significantly higher levels of organic byproducts (Bhuvaneshwari et al., 2022; Maurya et al., 2022; Zhang et al., 2022).

Some heterotrophs (acidogens or acetogens) create a number of low-molecular mass chemicals, such as volatile fatty acids, in the absence of the aforementioned electron acceptors (i.e., anaerobic circumstances) (VFA, e.g. acetic acid). Acetic acid is converted into methane gas by other heterotrophs (methanogens) (Singh et al., 2022). Because methanogens are poisoned by oxygen, most of their formation takes place in anaerobic environments. Fecal heterotrophs, on the other hand, are anaerobic heterotrophs that can receive electrons from a variety of sources (Zhang et al., 2021). A nitrifier is a type of chemolithoautotroph that relies on carbon dioxide for its carbon source and either ammonia-nitrogen or nitrite-nitrogen for its energy source or electron

donor. Denitrification occurs when autotrophs oxidize ammonia-nitrogen to nitrate-nitrogen (or nitrite-nitrogen) and the ensuing oxidized forms of nitrogen are reduced to nitrogen gas by heterotrophs during the denitration process (Khalaf et al., 2021). A collection of heterotrophic bacteria is used in Bio-P removal, and these bacteria are continuously exposed to anaerobic and aerobic conditions to enrich their growth. Heterotrophs that cause EBPR can utilize some CODs of municipal wastewater directly under anaerobic conditions. However, most of the organic compounds must first be fermented to low molecular- mass fatty acids, mainly acetic acid. Under anaerobic conditions, the Bio-P organisms can now use the energy released from the hydrolysis of intracellular polyphosphate to transport acetic acid across their cell membranes and produce polyhydroxyalkanoates (PHA) in general and, usually, polyhydroxybutyrate (PHB) (Baek et al., 2021).

5. Modification and new forms of SBRs

The concomitant utilization of stored glycogen provides the reduced nucleotides needed for PHB formation. When anaerobic conditions are switched to aerobic conditions, PHB serves as an energy source for cell growth, the transport of extracellular phosphorus, the formation of glycogen reserves, and the production of intracellular polyphosphate. Operating strategies used to establish EBPR consortia often select for denitrifiers. The resulting denitrification complicates EBPR because the denitrifiers 'steal' a portion of the COD contained in the wastewater and, possibly, some of the conversion products before they can be used by the

Bio-P organisms to increase further their relative abundance. This, of course, limits the total mass of phosphorus that can be removed in such EBPR systems (Zheng et al., 2021). The growths of a compact, good settling biomass, and the control of filamentous organisms, are critical performance factors in activated sludge systems.

Chudoba et al. (1973) demonstrated in their experiments that cyclic change of the concentration of growth substrates is a selection factor in favour of or against certain strains of filamentous bacteria. Through their experiments, they showed that filamentous bulking can be successively avoided when the activated sludge organisms are periodically exposed of high and low concentrations of substrate. Slight differences in the kinetic parameters of filamentous and non-filamentous bacteria studied are the reasons for the effects observed. Chiesa demonstrated the value of both feast and famine in the selection of non-filamentous organisms. He proposed an integrated hypothesis that explained how the relative growth rates and death rates of floc-formers and different types of filament would decrease the relative abundance of filaments in both high loaded and extended-aeration activated sludge treatment systems (Liu et al., 2020). Jones, Wilderer and Schroeder (Jones et al., 1990) illustrated that good settling activated sludge is best achieved when the microorganisms are regularly exposed to reasonably long-lasting near-starvation conditions as shown in Figure 2. They hypothesized that the extracellular polymeric substances (EPS) needed for the microorganisms to become embedded in and become an integral part of activated sludge flocs are generated preferentially whenever the concentration of readily biodegradable substances becomes limiting in the bulk liquid, and starvation begins.

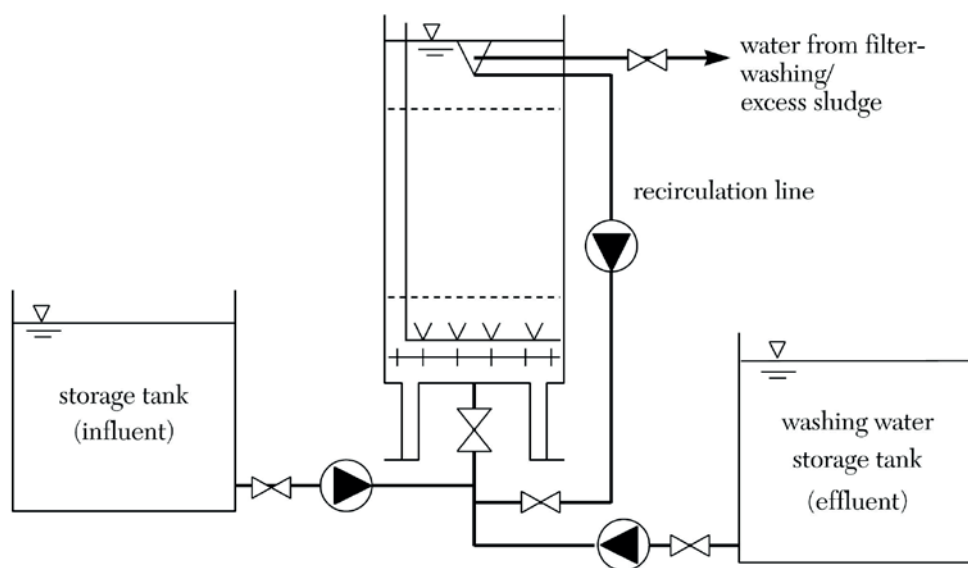

Figure 2. Schematic over view of an modified upflow SBBR (National & Pillars, 2015)

The effects of cyclic exposure of microorganisms to different process conditions on bioreactor performance are compiled. Each of the periodically imposed selective pressures described in this table has an important role during start-up and normal operation. The operating strategy implemented during start-up defines the microbial population that will ultimately be selected and enriched and, as a result, defines the treatment limits and capabilities of the system. The collective physiological state of the resulting microbial consortium can be modified and adjusted by making appropriate changes in the operating strategies employed after start-up (Heidari et al., 2021).

The flow rate (Q), concentration (C), and composition of the influent to municipal and industrial wastewater treatment plants vary throughout the day, week, and season. Any variation in effluent parameters should not exceed the site-specific discharge restrictions, no matter how little as shown in Figure 3.

The HRT in a biological reactor is often connected positively with the flow rate and mass loading of the influent (the product QC). Consequently, when the loading is higher, microorganisms need more time to carry out their separate metabolic activities (Su et al., 2018). CFS plants face considerable issues when the influent mass flow rate is inconsistent. Once the bioreactor size has been determined, performance is dependent on the actual HRT and influent mass loading. During periods of high loading,

a reactor that is under-designed in relation to the peak mass loads may exceed the established discharge limits. For safety concerns, continuous flow plants are commonly constructed to handle significant loading events, even if these occurrences occur very infrequently (Su et al., 2018). Its microbiological system responds to the low loading by shifting the distribution of organism types when the daily food supply is generally inadequate in such a system. As a result, the plant's capacity is not fully utilized, and the microbial population enriched in the reactor may have a restricted capacity to respond to shock loads when the desired groups of organisms are underrepresented as peak loadings occur. In parallel treatment systems (reactor and clarifier) in modular continuous flow-activated sludge facilities, the problem may be addressed if the number of systems in operation could be raised or lowered based on demand, while those not in use remained idle (Su et al., 2018). When compared to continuous flow systems, SBRs allow for almost instantaneous finetuning of important functions such as filament control or the change of nutrient removal by adjusting time limits or level controllers. In addition, the number of tanks in operation and the high-water level and/or low water level for each tank can be adjusted to vary cycle time so that actual field conditions are met. Changes can be made to the time limits set. Phases can be swapped out if necessary (e.g. from idle to settle, or from settle to react) (Su et al., 2018).

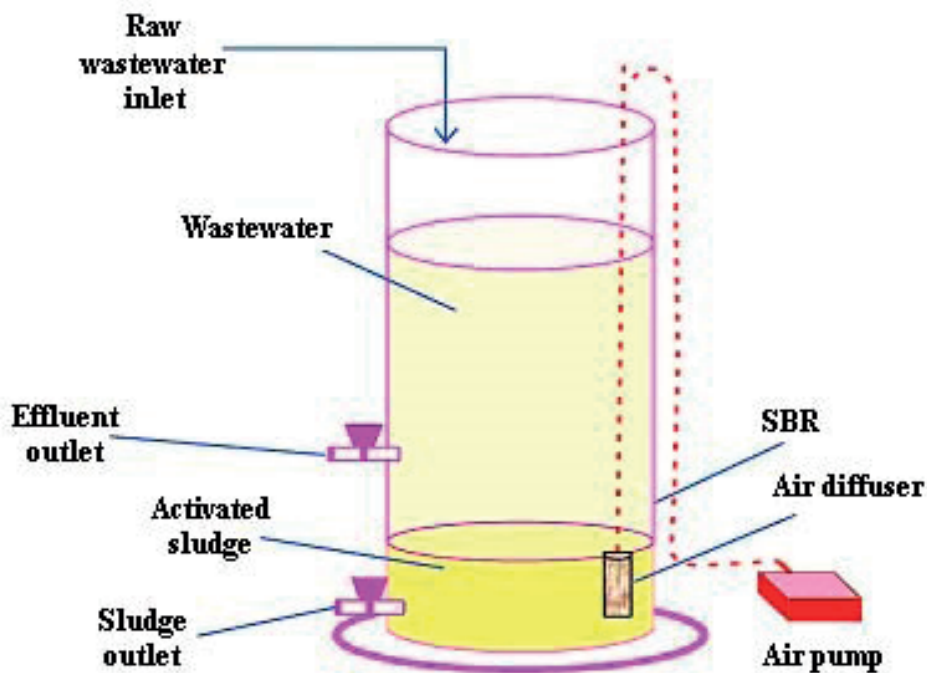

Figure 3. Typical cylindrical type SBR (Su et al., 2018)

6. Operation parameter modification and its effects

This can be done for example by adding a static fill phase of raising the ratio of time spent in the static fill phase to that of the aerated fill phase, which increases the maximum growth rate. A separate react phase (i.e. one without the concomitant entry of untreated wastewater) or an increased period for the aerated react phase might also 'deepen' the minimum growth rate. The final effluent's clarity and solids concentration can be adjusted by varying the settling time. An integral part of the SBR system is sludge thickening. There are many ways to reduce volumetric loading of the STP, including draining extra sludge at the end or even during idle periods. The SBR's ability to govern biological wastewater treatment processes is quite simple when the right operational techniques are used (Hu et al., 2021). The following are some of the benefits of SBR technology over more traditional continuous flow methods:

1. The correct F/M ratio (i.e., the food-to-microorganism ratio) during fill is essential for controlling filamentous sludge thickening through the use of feast/famine-based selective pressures.
2. Periodic processes site during fill and allow endogenous metabolic responses during a response to include the creation of EPS.
3. Cooperative denitrification and nitrification can be achieved by adjusting aeration strength during one cycle.
4. Short- and long-term seasonal fluctuations in wastewater composition, concentration, and load can be easily accommodated by adjusting the system setup and operating policy.
5. To 'polish' phosphorus removal through the direct addition of sequestering agents during the fill or react stages by eliminating separate load equalization facilities and using each SBR tank as an equalization basin, if permitted.
6. Denitrification or EBPR can use carbon-based energy to remove nutrients, which reduces oxygen demand and sludge generation.
7. Alter cycle time, duration of various process steps, aeration time, and over to meet actual needs to withstand shock loads produced by fluctuations in organic and hydraulic load
8. To minimize eddy currents and turbulence in order to reduce the amount of efficacious suspended solids
9. During the settling process to reduce the water content of the sludge that is discharged from the reactor.

Several countries around the world, including the United States, have implemented stricter criteria for the treatment and recycling of treated wastewater. SBR-based

wastewater treatment plants, in contrast to conventional ones, can improve treated water quality without or with minor modifications to the installed infrastructure by simply altering the process control parameters during one or more phases of the treatment cycle. SBR-based wastewater treatment plants (Su et al., 2018). A small footprint, reduced investment cost, less complexity in operation and substantial control performance are some of the advantages of the SBR process over conventional treatment. The procedure may also remove a considerable amount of biological nutrients if it is appropriately constructed. Even though the SBR process is well-established and new versions are constantly being produced, there are still a number of challenges that need to be resolved. There must be more work done to understand the variety and dynamics of the microbial community within the SBR system in order to ensure process reliability for simultaneous removal of both N and P. Research and improved design may be guided by the concepts of ecologically engineered systems that are stable due to the presence of several species that collect phosphorus (functional richness). This could make the system more tolerant to changes in external variables, such as temperature and pH swings, hazardous contaminants, the presence of nitrite and nitrate, and the predominance of VFAs, among others. When it comes to ensuring the removal of target pollutants from wastewater, proper process management plays a critical role in SBR technology. Using real-time control mechanisms, the SBR process may be made more robust, dependable, and efficient. In addition to enhancing energy efficiency, this will assist expand the SBR process's applications. Next-generation control techniques for SBR should include the development of a real-time feedback-based control strategy known as an intelligent control system. A high degree of reliability will be maintained in the SBR process, which will be able to respond to changing environmental circumstances and to a wide range of wastewater quality (Su et al., 2018).

7. Sequencing Batch Biofilm Reactor

SBR technology is being used in a wide variety of treatment processes because of its operational flexibility. Flow equilibration, biological treatment, and secondary clarification can all be accomplished by SBR in a single tank by adjusting the aeration and phase times. A variety of treatment technologies have been combined in recent years and evaluated in the lab to see if SBR technology can be used in new ways. Sequencing Batch Biofilm Reactor (SBBR) is a type of SBR that incorporates both suspended and attached growth (CSAG). At the solid-liquid contact, biofilm develops by adhering to a substrate (Zhao et al., 2021). Microorganisms

with sluggish growth rates can thrive in the bio-aggregates regardless of the HRT and sedimentation parameters. The choice of support material and the size of the support material depend on the wastewater properties and treatment goals. Either the support material is put into the reactor or the reactor fluid is used to suspend the reactor. There are only three stages in a normal SBBR cycle: Fill, React, and Draw. This type of boiler has a phenomenon known as plug flow. Washing the support medium is similar to settling time in an SBR, and this can be compared (Ciggin et al., 2021). Using SBBR systems with high TSS and microbial growth is not recommended because of the possibility of significant head loss and sludge sloughing-off. After the first pilot-scale SBBR was utilized to treat leachate from the Landfill, Germany, there have been a number of subsequent installations. A carrier media that carries microorganisms, decreases washout, protects them from toxins and pH and temperature changes, and allows them to thrive. Using a smaller reactor or more treatment capacity with the same size reactor is achievable due to the retention of the media, which allows for a shorter HRT. If you've got a lot of variation in the quality of your water, a biofilm-based treatment system is the best option. To help absorb shock loads, media such as activated carbon or zeolite, depending on the influent ammonia concentration, can be carefully selected. These buffers temporarily adsorb the shock load-producing element, and then gradually desorb the contaminants along with their simultaneous or subsequent biodegradation. When used to treat raw landfill leachate, powdered activated carbon (PAC) outperformed conventional SBR when it came to removing NH₃-N, colour, and COD (Ni et al., 2021). With the use of intelligent dynamic control systems, COD, TP, and TN removal efficiencies have been shown to increase with significant energy savings. Bio-floc technology (BFT), a modified SBR system, has found useful applications in aquaculture, where protein feed for fish and wastewater treatment are both considered prohibitively expensive. Microorganisms that can take up nitrogenous compounds in wastewater and convert them to microbial protein are referred to as Bio-floc. It is possible to feed fish with bio-floc organisms. SBR, when used as an external growth reactor for bio-floc, has been shown to remove nitrogen with a removal efficiency of up to 98% when the C/N ratio is kept between 10 and 15. The BFT in the SBR reactor also enabled the conversion of nitrogen in aquaculture suspended solids into bacterial biomass, which could potentially be used to feed fish, thereby increasing the efficiency of nitrogen nearly reaching 100% nitrate removal within six hours. P-nitrophenol (PNP), a hazardous chemical widely used as a synthetic intermediate in the manufacturing process in the agricultural, pharmaceutical, and dye industries, was treated using SBR and SBBR, which were developed for the treatment of industrial wastewater

containing phenolic compounds. With a loading rate of 0.368 kg/m³day⁻¹, SBR and SBBR were able to remove all of the PNP from the influent (with polyethylene rings). Though only slightly compromised, the average efficacy of the SBR and SBBR in removing NH₃-N was still 96% in both cases. For wastewater with a high nitrogen content and low COD, SBR has been successful, such as the anaerobic SBR-based SNAD system, which was used to treat the wastewater from the opto-electronic industry with a C/N ratio of nearly 0.2. TFT-LCD wastewater containing DMSO, MEA, and tetramethyl ammonium hydroxide (TMAH) was subjected to the same treatment process as DMSO, MEA, and TMAH in a similar study conducted by (TMAH). A/O and aerobic-based SBR systems were both used in this study (Patel et al., 2021). While efficient DMSO and TMAH degradation were only possible under anaerobic conditions, effective MEA degradation was possible under all three conditions examined with relative ease. With time-sequenced anoxic/oxic and high biomass, hybrid systems like the Porous biomass carrier SBR (PBCSBR) are being investigated to improve nutrient removal efficiency. The treatment of dairy manure with natural fibers as biofilm carriers was the subject of another study. In a psychrophilic ASBR, flushed dairy manure produced more methane even after only six days of treatment, despite the low temperature. For biomass retention, ASBRs have been shown to be able to decouple HRT and SRT. The immobilisation of microbes was aided by selective pressures applied by ASBR in a specific order of operation. To recover wastewater from the textile industry, an aerobic SBR process, coupled with the photo-Fenton process and reverse osmosis (RO), was used. For example, cyclic feast and famine regimes, high shear stress, and short settlement times promote the formation of floc granules, which are nothing but dense microbial consortia consisting of different bacteria species that perform different roles in degrading complex wastes. Nitrogen removal in granular SBR has been shown to be facilitated by alternating anoxic/oxic conditions in conjunction with step-feeding modes (AASF) (Su et al., 2018).

Cyclic Activated Sludge System Cyclic Activated Sludge System (CASS) features a single basin with variable volume operating in an alternating manner. It delivers a unique combination of a plug flow in the early zone followed by an entirely mixed reactor basin with secondary and major aeration zones. The activated sludge from the main aeration zone is recirculated into a selection zone placed before the complete-mix unit where it gets mixed with the raw wastewater entering the facility. The presence of a suitably designed high rate plug-flow selector permits a steady and generally uniform level of metabolic activity of the sludge in the complete-mix aeration tank resulting in faster digestion of the organic contents and higher settleability of the flocs.

The process is consequently generally indifferent to any fluctuations in the flow rate and organic concentration of the influent raw water (Su et al., 2018). Apart from these advantages, a greater degree of simultaneous nitrification and denitrification, as well as biological phosphorus removal, is accomplished by employing a CASS as compared to the standard SBR process. This method can be applied to both industrial and municipal wastewater treatment systems (Su et al., 2018).

7.1 UNITANK systems

The UNITANK systems include the advantages of SBR, three ditch oxidation treatments and a regular aeration tank. The basic UNITANK structure consists of a single tank divided into three hydraulically connected compartments in series. Each compartment has an aeration system and no provision for external sludge recirculation. The outside compartments alternately operate as aeration and sludge settling tanks while the middle one act as an aeration unit exclusively. A single operation cycle comprises two primary stages which include three basic steps which are conducted in a symmetrical manner commencing from either of the outer compartments in each stage. There is no separate sedimentation tank with a scraper but the exterior compartments contain sludge slots and fixed effluent weirs. For elimination of N and P, an enhanced variant of UNITANK is utilized (A.H. Jagaba et al., 2021). This structure possesses additional anaerobic/anoxic chambers with internal recirculation of mixed liquor. UNITANK is ideal for small- to middle-sized wastewater treatment plants with the advantages of simple structure, reduced land occupation, cost-efficient, and reliable operation. The UNITANK system is being utilized in several nations including China, Mexico, Argentina, Brazil, Vietnam, etc. Intermediate Cycle Extended Aeration System (ICEAS) (ICEAS). A further enhancement of the typical SBR batch process is Intermediate Cycle Extended Aeration System (ICEAS) technology which handles continuous inflow of the wastewater. Variable inflow is managed by a distributor box which distributes flow uniformly throughout all the tanks to avoid overloading in any particular tank. A pre-react zone with high F/M works as a selector (Saleh & Mahmood, 2005). Thus, increased settling of sludge and suppression of filamentous growth can be obtained. The main-react zone located following the pre-react zone is managed in three primary operation modes, Aeration, Settle and Draw. The equal loading of all the basins during continuous inflow simplifies the operation and process control. It also makes maintenance easy. There is significant capital cost reduction as compared to the conventional SBR process since only a single set of tanks is required. The difficult process control associated with the conventional SBR process is overcome

as at any given point of time all the basins receive equal loading and flow. The ICEAS is gaining popularity in China, US, UK, Peru, Qatar, etc. for replacing the old STPs or for new facilities where limited space is available or increased effluent quality is required.

A reactor's daily cycle time, basin count, decant volume, reactor diameter, and retention duration are easily determinable if the primary design parameters are known. Aeration, decanter, and piping can then be sized. Aeration equipment needs to be sized according on the specifics of the site, such as the elevation above mean sea level, temperature of the wastewater, and total concentration of dissolved solids. The fill-and-draw principle underpins the operation of SBRs, and it consists of the idle, fill, react, settle, and draw processes. During most of these processes, it is possible to use more than one operating strategy. Treatability studies are often needed to determine the best operating sequence for industrial wastewater applications. For most municipal wastewater treatment plants, treatability studies are not necessary to define the operating sequence because municipal wastewater flowrates and characteristic variations are usually predictable and most municipal designers employ conservative design techniques. Steps between the Draw and Fill stages, effluent are withdrawn from the system, and influent wastewater is added. Idle step duration varies with influent flowrate and operation strategy. The utilization of varying idle times allows for equalization to be achieved at this point. There are a variety of ways to accomplish mixing during the idle stage to prepare the biomass and sludge for use. Filtration wastewater is fed into the reactor at this point. The Fill step can be performed in either of the following ways, depending on the operational strategy: aerated fill, static fill, and a blend of these. Biomass and influent wastewater are mixed during static fill. As a result, there will be a high concentration of food (substance) in the mixture when mixing begins. An environment with a high food to microorganisms (F:M) ratio favours floc-forming organisms over filamentous ones, which helps the sludge settle more easily. To make things even more complicated, static filling encourages organisms to develop internal storage products when the substrate is high, which is essential for the biological elimination of phosphorus. Conventional activated sludge systems can be compared to a static fill system using 'selector' compartments. Biological reactions are sparked by the mixing of influent organics with the biomass. An alternate electron acceptor, nitrate-nitrogen, is used by microorganisms during mixed fill to biologically decompose organic materials. Denitrification may take place in this environment because of the anoxic circumstances. In biology, denitrification refers to the process by which nitrate-nitrogen is converted to nitrogen gas. Nitrate-nitrogen is employed as an electron acceptor by microorganisms in anoxic conditions, where oxygen is not present. The anoxic

zone, where denitrification takes place, is analogous to the mixed fill in a standard BNR activated sludge system. It is possible to achieve anaerobic conditions during the mixed fill phase of the process.

7.2 Nitrification and de nitrification process

When nitrate-nitrogen is used up by the bacteria, the electron acceptor is sulfate. These conditions are known as anaerobic since there is no oxygen and just sulfate as an electron acceptor. Aerobic reactions are completed in React by aerating reactor contents to start the aeration process. In the React stage, aeration can be sped up by using aerated Fill instead. There are two reaction options accessible in the React step: mixed react and aerated react. During aerated react, the aerobic processes that were started during aerated fill are finished and nitrification can occur (Su et al., 2018). During nitrification, ammonia-nitrogen is transformed into nitrogen nitrite and then nitrogen nitrate. It is possible to achieve anoxic conditions for denitrification using the mixed react mode. Mixture reactions can also be used to remove phosphorus in anaerobic conditions. Typically, in the SBR, the settle is delivered in a restful state. Sludge may be more concentrated and clearer in some circumstances if the settling process is slowed down by moderate mixing. Because of this, the settling process in an SBR is not hindered by the flow of influent or effluent currents. Decanting wastewater from the treated effluent is the main distinguishing element amongst SBR producers. There are two types of decanters: floating and fixed. Contact stabilization and extended aeration may both be simulated using this time-oriented, periodic process, as can practically all conventional continuous-flow activated sludge systems (Su et al., 2018). The SBR has numerous advantages, including: It's more cost-efficient, more effective, and has a successful track record when it comes to creating idle conditions for organisms capable of nutrient removal.

8. Conclusion

A combination of these qualities makes the SBR a highly effective method for removing contaminants from wastewater. The operating policy can be changed to meet new effluent regulations, handle variations in wastewater properties, and accept seasonal flow rate oscillations all without increasing the physical plant's size. What's best for your business or municipality will vary based on your wastewater treatment plant's requirements and goals. SBR's have proven to be an incredibly cost-effective and successful method for treating even the most difficult to treat wastewaters.

Acknowledgements

The authors extend their appreciation to the Deanship of Scientific Research at Imam Mohammad Ibn Saud Islamic University for funding this work through Research Group no. RG-21-09-89.

References

- Abdulgader M., Yu Q.J., Zinatizadeh A.A., Williams P. & Rahimi Z., 2020, Performance and kinetics analysis of an aerobic sequencing batch flexible fibre biofilm reactor for milk processing wastewater treatment. *J. Environ. Manage.* 255: 109793. <https://doi.org/https://doi.org/10.1016/j.jenvman.2019.109793>
- Al-Mamun A., Jafary T., Baawain M.S., Rahman S., Choudhury M.R., Tabatabaei M. & Lam S.S., 2020, Energy recovery and carbon/nitrogen removal from sewage and contaminated groundwater in a coupled hydrolytic-acidogenic sequencing batch reactor and denitrifying biocathode microbial fuel cell. *Environ. Res.* 183: 109273. <https://doi.org/https://doi.org/10.1016/j.envres.2020.109273>
- Baek G., Kim J. & Lee C., 2021, Effectiveness of electromagnetic in situ magnetite capture in anaerobic sequencing batch treatment of dairy effluent under electro-syntrophic conditions. *Renew. Energy* 179: 105–115. <https://doi.org/https://doi.org/10.1016/j.renene.2021.07.052>
- Barros A.R.M., Rollemberg S.L. de S., de Carvalho C. de A., Moura I.H.H., Firmino P.I.M. & dos Santos A.B., 2020, Effect of calcium addition on the formation and maintenance of aerobic granular sludge (AGS) in simultaneous fill/draw mode sequencing batch reactors (SBRs). *J. Environ. Manage.* 255: 109850. <https://doi.org/https://doi.org/10.1016/j.jenvman.2019.109850>
- Bhuvaneshwari S., Majeed F., Jose E. & Mohan A., 2022, Different treatment methodologies and reactors employed for dairy effluent treatment-A review. *Journal of Water Process Engineering* 46: 102622. <https://doi.org/https://doi.org/10.1016/j.jwpe.2022.102622>
- Bucci P., Coppotelli B., Morelli I., Zaritzky N. & Caravelli A., 2021, Heterotrophic nitrification-aerobic denitrification performance in a granular sequencing batch reactor supported by next generation sequencing. *Int. Biodeterior. Biodegradation* 160: 105210. <https://doi.org/https://doi.org/10.1016/j.ibiod.2021.105210>
- Chen D., Li H., Xue X., Zhang L., Hou Y., Chen H., Zhang Y., Song Y., Zhao S. & Guo J., 2022, Enhanced simultaneous partial nitrification and denitrification performance of aerobic granular sludge via tapered aeration in sequencing batch reactor for treating low strength and low COD/TN ratio municipal wastewater. *Environ. Res.*

- 209: 112743. <https://doi.org/https://doi.org/10.1016/j.envres.2022.112743>
- Chudoba J., Grau P. & Ottova V., 1973, Control of activated sludge filamentous bulking — II. Selection of microorganisms by means of a selector. *Water Res* 7(10): 1398–406.
- Ciggin A.S., Iravanian A., Doğruel S. & Orhon D., 2021, Co-metabolism of olive mill wastewater in sequencing batch reactor under aerobic conditions after Fenton-based oxidation. *J. Water Process Eng.* 43: 102277. <https://doi.org/https://doi.org/10.1016/j.jwpe.2021.102277>
- Ding J., Chen B., Zhang Y., Ye X., Li Y., Zhou D., Ding Y., Zhu W. & Zhang H., 2021, Effects of poly (1,4-butanediol succinate) carrier on the nitrogen removal performance and microbial community of sequencing batch reactors. *J. Clean. Prod.* 291: 125279. <https://doi.org/https://doi.org/10.1016/j.jclepro.2020.125279>
- Guo Q., Yin Q., Du J., Zuo J. & Wu G., 2022, New insights into the r/K selection theory achieved in methanogenic systems through continuous-flow and sequencing batch operational modes. *Sci. Total Environ.* 807: 150732. <https://doi.org/https://doi.org/10.1016/j.scitotenv.2021.150732>
- Heidari M.R., Malakootian M., Boczkaj G., Sun X., Tao Y., Sonawane S.H. & Mehdizadeh H., 2021, Evaluation and start-up of an electro-Fenton-sequencing batch reactor for dairy wastewater treatment. *Water Resour. Ind.* 25: 100149. <https://doi.org/https://doi.org/10.1016/j.wri.2021.100149>
- Hou Y., Zeng Q., Li H., Wu J., Xiang J., Huang H. & Shi S., 2022, Metagenomics-based interpretation of the impacts of silica nanoparticles exposure on phenol treatment performance in sequencing batch reactor system. *Chem. Eng. J.* 428: 132052. <https://doi.org/https://doi.org/10.1016/j.cej.2021.132052>
- Hu K., Sarrà M. & Caminal G., 2021, Comparison between two reactors using *Trametes versicolor* for agricultural wastewater treatment under non-sterile condition in sequencing batch mode. *J. Environ. Manage.* 293: 112859. <https://doi.org/https://doi.org/10.1016/j.jenvman.2021.112859>
- Jagaba A.H., Kutty S.R.M., Lawal I.M., Abubakar S., Hassan I., Zubairu I., Umaru I., Abdurrahman A.S., Adam A.A., Ghaleb A.A.S., Almahbashi N.M.Y., Al-Dhawi B.N.S. & Noor A., 2021a, Sequencing batch reactor technology for landfill leachate treatment: A state-of-the-art review. *J. Environ. Manage.* 282: 111946. <https://doi.org/10.1016/j.jenvman.2021.111946>
- Jagaba Ahmad Hussaini, Kutty S.R.M., Noor A., Birniwa A.H., Affam A.C., Lawal I.M., Kankia M.U. & Kilaco A.U., 2021b, A systematic literature review of biocarriers: Central elements for biofilm formation, organic and nutrients removal in sequencing batch biofilm reactor. *J. Water Process Eng.* 42: 102178. <https://doi.org/https://doi.org/10.1016/j.jwpe.2021.102178>
- Ji J., Peng L., Redina M.M., Gao T., Khan A., Liu P. & Li X., 2021, Perfluorooctane sulfonate decreases the performance of a sequencing batch reactor system and changes the sludge microbial community. *Chemosphere* 279: 130596. <https://doi.org/https://doi.org/10.1016/j.chemosphere.2021.130596>
- Jones, W.L., Schroeder, E.D. & Wilderer P.A., 1990, Denitrification in a batch wastewater treatment system using sequestered organic substances. *Research Journal of the Water Pollution Control Federation* 62(3): 259–267. <https://www.jstor.org/stable/25043830>
- Karadag D., Koroğlu O.E., Ozkaya B. & Cakmakci M., 2015, A review on anaerobic biofilm reactors for the treatment of dairy industry wastewater. *Process Biochem.* 50: 262–271. <https://doi.org/https://doi.org/10.1016/j.procbio.2014.11.005>
- Khalaf A.H., Ibrahim W.A., Fayed M. & Eloffy M.G., 2021, Comparison between the performance of activated sludge and sequence batch reactor systems for dairy wastewater treatment under different operating conditions. *Alexandria Eng. J.* 60: 1433–1445. <https://doi.org/https://doi.org/10.1016/j.aej.2020.10.062>
- Khalil M. & Liu Y., 2021, Greywater biodegradability and biological treatment technologies: A critical review. *Int. Biodeterior. Biodegradation* 161: 105211. <https://doi.org/https://doi.org/10.1016/j.ibiod.2021.105211>
- Lee D.-J., Chen Y.-Y., Show K.-Y., Whiteley C.G. & Tay J.-H., 2010, Advances in aerobic granule formation and granule stability in the course of storage and reactor operation. *Biotechnol. Adv.* 28: 919–934. <https://doi.org/https://doi.org/10.1016/j.biotechadv.2010.08.007>
- Li D., Zhang S., Li S., Zeng H. & Zhang J., 2019, Aerobic granular sludge operation and nutrients removal mechanism in a novel configuration reactor combined sequencing batch reactor and continuous-flow reactor. *Bioresour. Technol.* 292: 122024. <https://doi.org/https://doi.org/10.1016/j.biortech.2019.122024>
- Liu Y., Gayle A.A., Wilder-Smith A. & Rocklöv J., 2020, The reproductive number of COVID-19 is higher compared to SARS coronavirus. *J. Travel Med.* 1–4. <https://doi.org/10.1093/jtm/taaa021>
- Maurya R., Zhu X., Valverde-Pérez B., Ravi Kiran B., General T., Sharma S., Kumar Sharma A., Thomsen M., Venkata Mohan S., Mohanty K. & Angelidaki I., 2022, Advances in microalgal research for valorization of industrial wastewater. *Bioresour. Technol.* 343: 126128. <https://doi.org/https://doi.org/10.1016/j.biortech.2021.126128>
- Miao L., Wang S., Li B., Cao T., Xue T. & Peng Y., 2015a, Advanced nitrogen removal via nitrite using stored polymers in a modified sequencing batch reactor treating

- landfill leachate. *Bioresour. Technol.* 192: 354–360. <https://doi.org/10.1016/j.biortech.2015.05.013>
- Miao L., Wang S., Li B., Cao T., Xue T. & Peng Y., 2015b, Advanced nitrogen removal via nitrite using stored polymers in a modified sequencing batch reactor treating landfill leachate. *Bioresour. Technol.* 192: 354–360. <https://doi.org/https://doi.org/10.1016/j.biortech.2015.05.013>
- Nancharaiah Y.V & Kiran Kumar Reddy G., 2018, Aerobic granular sludge technology: Mechanisms of granulation and biotechnological applications. *Bioresour. Technol.* 247: 1128–1143. <https://doi.org/https://doi.org/10.1016/j.biortech.2017.09.131>
- National G. & Pillars H., 2015, Sequencing Batch Reactor Technology. *IWA Publ.* 1: 3–93.
- Ni M., Pan Y., Zhang X., Wen L., Yang W., Chen Y., Huang Y. & Song Z., 2021, Effects of P/C ratios on the growth, phosphorus removal and phosphorus recovery of a novel strain of highly efficient PAO. *Process Biochem.* 111: 109–117. <https://doi.org/https://doi.org/10.1016/j.procbio.2021.08.010>
- Patel K., Patel N., Vaghamsi N., Shah K., Duggirala S.M. & Dudhagara P., 2021, Trends and strategies in the effluent treatment of pulp and paper industries: A review highlighting reactor options. *Curr. Res. Microb. Sci.* 2: 100077. <https://doi.org/https://doi.org/10.1016/j.crmicr.2021.100077>
- Piotrowski R., Sawicki H. & Żuk K., 2021, Novel hierarchical nonlinear control algorithm to improve dissolved oxygen control in biological WWTP. *Process Control* 105: 78–87. <https://doi.org/https://doi.org/10.1016/j.jprocont.2021.07.009>
- Pochwatka P., Kowalczyk-Juśko A., Sołowiej P., Wawrzyniak A. & Dach J., 2020, Biogas plant exploitation in a middle-sized dairy farm in Poland: Energetic and economic aspects. *Energies* 13(22): 6058.
- Sakalova H., Malovanyy M., Vasylynych T., Palamarchuk O., Semchuk J., 2019, Treatment of effluents from ions of heavy metals as display of environmentally responsible activity of modern businessman. *Journal of Ecological Engineering*: 20(4), 167–176. <https://doi.org/10.12911/22998993/102841>
- Saleh M.M.A. & Mahmood U.F., 2005, Modified sequential batch reactor (MSBR) a new process of wastewater treatment. 9th Int. Water Technol. Conf., p. 105–113.
- Singh V., Ormeci B., Mishra S. & Hussain A., 2022, Simultaneous partial Nitrification, ANAMMOX and denitrification (SNAD) – A review of critical operating parameters and reactor configurations. *Chem. Eng. J.* 433: 133677. <https://doi.org/https://doi.org/10.1016/j.cej.2021.133677>
- Su J.J., Huang J.F., Wang Y.L. & Hong Y.Y., 2018, Treatment of duck house wastewater by a pilot-scale sequencing batch reactor system for sustainable duck production. *Poult. Sci.* 97: 3870–3877. <https://doi.org/10.3382/ps/pey251>
- Vambol S., Vambol V., Suchikova Y. & Deyneko N., 2017, Analysis of the ways to provide ecological safety for the products of nanotechnologies throughout their life cycle, *Eastern European Journal of Enterprise Technologies* 1/10(85): 27–36. DOI: <https://doi.org/10.15587/1729-4061.2017.85847>
- Voytovych I., Malovanyy M., Zhuk V. & Mukha O., 2020, Facilities and problems of processing organic wastes by family-type biogas plants in Ukraine. *Journal of Water and Land Development* 45(IV–VI): 185–189. <https://doi.org/10.24425/jwld.2020.133493>
- Wang J., Zhou J., Wang Y., Wen Y., He L. & He Q., 2020, Efficient nitrogen removal in a modified sequencing batch biofilm reactor treating hypersaline mustard tuber wastewater: The potential multiple pathways and key microorganisms. *Water Res.* 177: 115734. <https://doi.org/https://doi.org/10.1016/j.watres.2020.115734>
- Wang L., Gu W., Liu Y., Liang P., Zhang X. & Huang X., 2022, Challenges, solutions and prospects of mainstream anammox-based process for municipal wastewater treatment. *Sci. Total Environ.* 820: 153351. <https://doi.org/https://doi.org/10.1016/j.scitotenv.2022.153351>
- Wang M., Keeley R., Zalivina N., Halfhide T., Scott K., Zhang Q., van der Steen P. & Ergas S.J., 2018, Advances in algal-prokaryotic wastewater treatment: A review of nitrogen transformations, reactor configurations and molecular tools. *J. Environ. Manage.* 217: 845–857. <https://doi.org/https://doi.org/10.1016/j.jenvman.2018.04.021>
- Zhang M., Wang X., Zhang D., Zhao G., Zhou B., Wang D., Wu Z., Yan C., Liang J. & Zhou L., 2022, Food waste hydrolysate as a carbon source to improve nitrogen removal performance of high ammonium and high salt wastewater in a sequencing batch reactor. *Bioresour. Technol.* 349: 126855. <https://doi.org/https://doi.org/10.1016/j.biortech.2022.126855>
- Zhang Y., Meng C., He Y., Wang X. & Xue G., 2021, Influence of cell lysis by Fenton oxidation on cryptic growth in sequencing batch reactor (SBR): Implication of reducing sludge source discharge. *Sci. Total Environ.* 789: 148042. <https://doi.org/https://doi.org/10.1016/j.scitotenv.2021.148042>
- Zhao J., Yuan Q., Sun Y., Zhang J., Zhang D. & Bian R., 2021, Effect of fluoxetine on enhanced biological phosphorus removal using a sequencing batch reactor. *Bioresour. Technol.* 320: 124396. <https://doi.org/https://doi.org/10.1016/j.biortech.2020.124396>
- Zheng Z., Li J. & Wang C., 2021, Rapid cultivation of the aerobic granules for simultaneous phenol degradation and ammonium oxidation in a sequencing batch reactor. *Bioresour. Technol.* 325: 124414. <https://doi.org/https://doi.org/10.1016/j.biortech.2020.124414>